

INCLUDING
*Communication
 Engineering*
 and
*TV & RADIO
 ENGINEERING*

RADIO-ELECTRONIC *Engineering*

Reg. U. S. Pat. Off.

MAY, 1955

"PROGRESS LINE" RECEIVER DESIGN
 7

A VIDEO PATCHING SYSTEM
 10

"COMPAC" MODULES
 FOR ELECTRONIC PRODUCTION
 12

MICROWAVE TESTING
 WITH MILLIMICROSECOND PULSES
 13

LOW-CAPACITANCE POWER SUPPLY
 16

IMPREGNATED PAPER CAPACITORS
 17

SYNTHESIZING CRYSTAL STABILITY
 20

DEPARTMENTS

TECHNICAL BOOKS 21

NEW PRODUCTS 22

NEWS BRIEFS 24

TV-AM-FM PRODUCTION 24

PERSONALS 27

COMMUNICATION REVIEW .. 28

NEW LITERATURE 29

CALENDAR 29

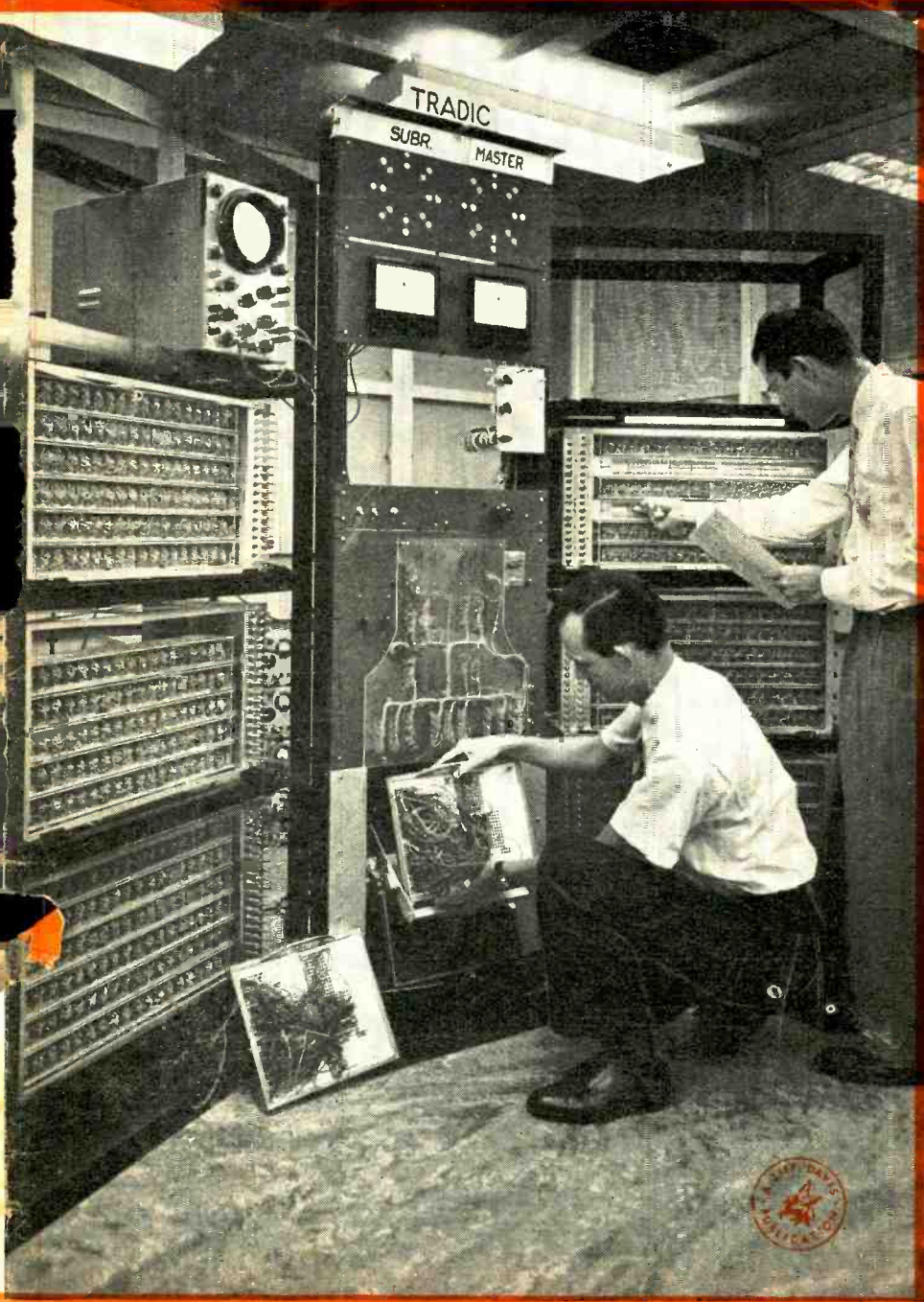

TRADIC, a transistorized digital computer developed at Bell Telephone Laboratories under the direction of J. H. Felker (left) for military aircraft, operates on less than 100 watts. J. R. Harris (right) places numbers into the machine by flipping simple switches.

OUR MILLIONTH FILTER SHIPPED THIS YEAR...

FILTERS

FOR EVERY APPLICATION



TELEMETERING FILTERS

UTC manufactures a wide variety of band pass filters for multi-channel telemetering. Illustrated are a group of filters supplied for 400 cycle to 40 KC service. Miniaturized units have been made for many applications. For example a group of 4 cubic inch units which provide 50 channels between 4 KC and 100 KC.

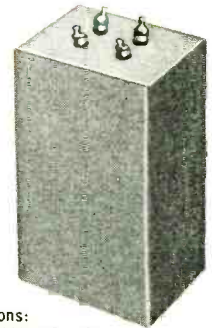
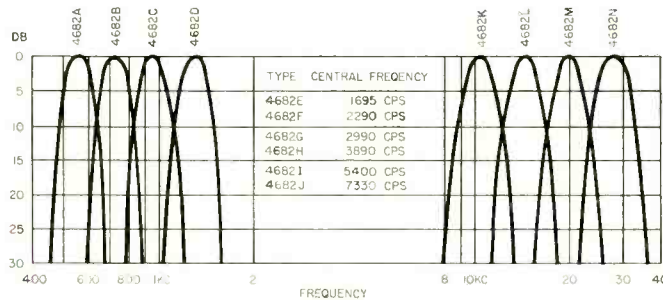

Dimensions:
(4682A) 1½ x 2 x 4"



Dimensions:
(3834) 1¼ x 1¾ x 2-3/16"
(2000, 1) 1¼ x 1¾ x 1⅝"

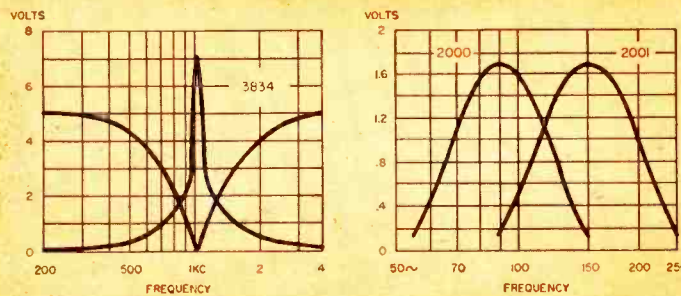

AIRCRAFT FILTERS

UTC has produced the bulk of filters used in aircraft equipment for over a decade. The curve at the left is that of a miniaturized (1020 cycles) range filter providing high attenuation between voice and range frequencies.

Curves at the right are that of our miniaturized 90 and 150 cycle filters for glide path systems.

CARRIER FILTERS

A wide variety of carrier filters are available for specific applications. This type of tone channel filter can be supplied in a varied range of band widths and attenuations. The curves shown are typical units.

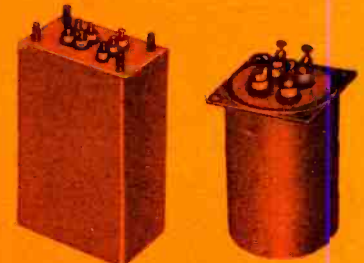
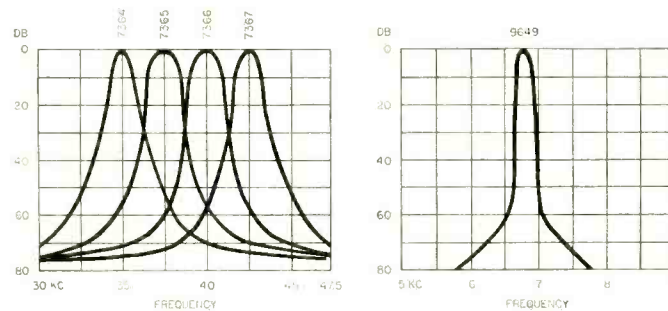

Dimensions:
(7364 series) 1⅝ x 1⅝ x 2¼"
(9649) 1½ x 2 x 4"

DISCRIMINATORS

These high Q discriminators provide exceptional amplification and linearity. Typical characteristics available are illustrated by the low and higher frequency curves shown.

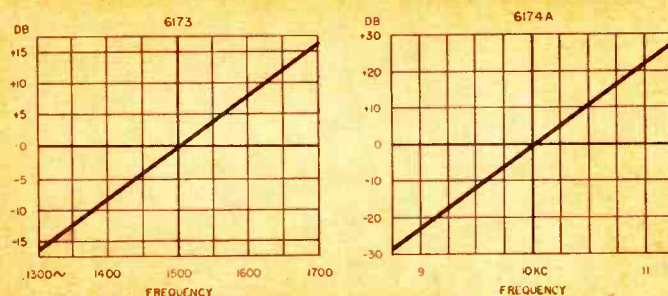

Dimensions:
(6173) 1-1/16 x 1⅝ x 3"
(6174A) 1 x 1¼ x 2¼"

For full data on stock UTC transformers, reactors, filters, and high Q coils, write for Catalog A.

UNITED TRANSFORMER CO.

150 Varick Street, New York 13, N. Y. EXPORT DIVISION: 13 E. 40th St., New York 16, N. Y. CABLES: "ARLAB"



PYE ERICSSON

SEVEN CHANNEL

VHF FM RADIO TELEPHONE SYSTEM

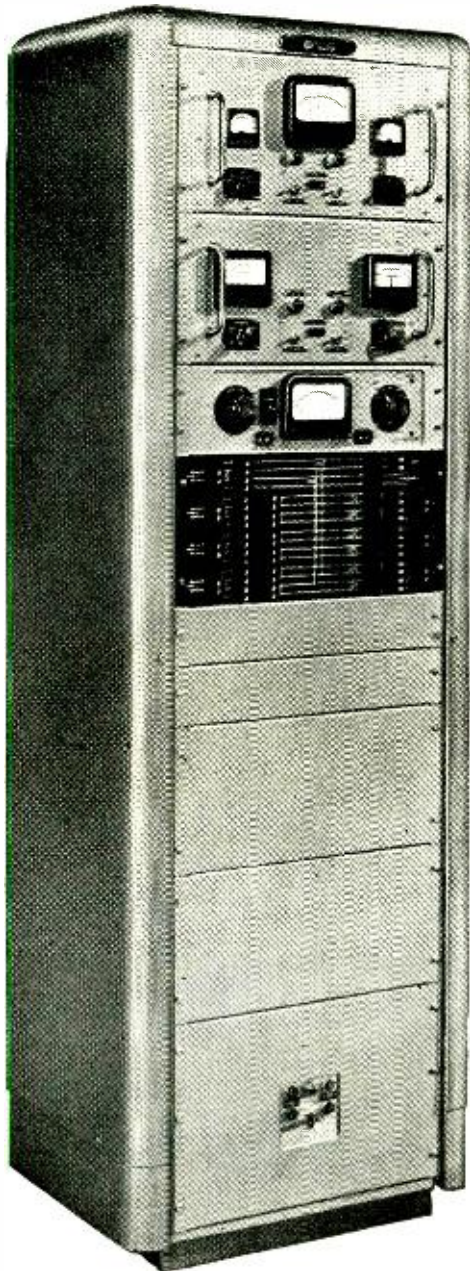

This 7-channel Radio Link System has been designed for economy both in initial cost and maintenance demands.

This has been achieved without sacrifice of essential facilities or relaxation of performance standards. Both Radio and Carrier equipment for the 7-channel terminal is housed in a single 6-foot cabinet as illustrated.

The equipment is fully tropicalized and suitable for continuous unattended operation in all parts of the world.

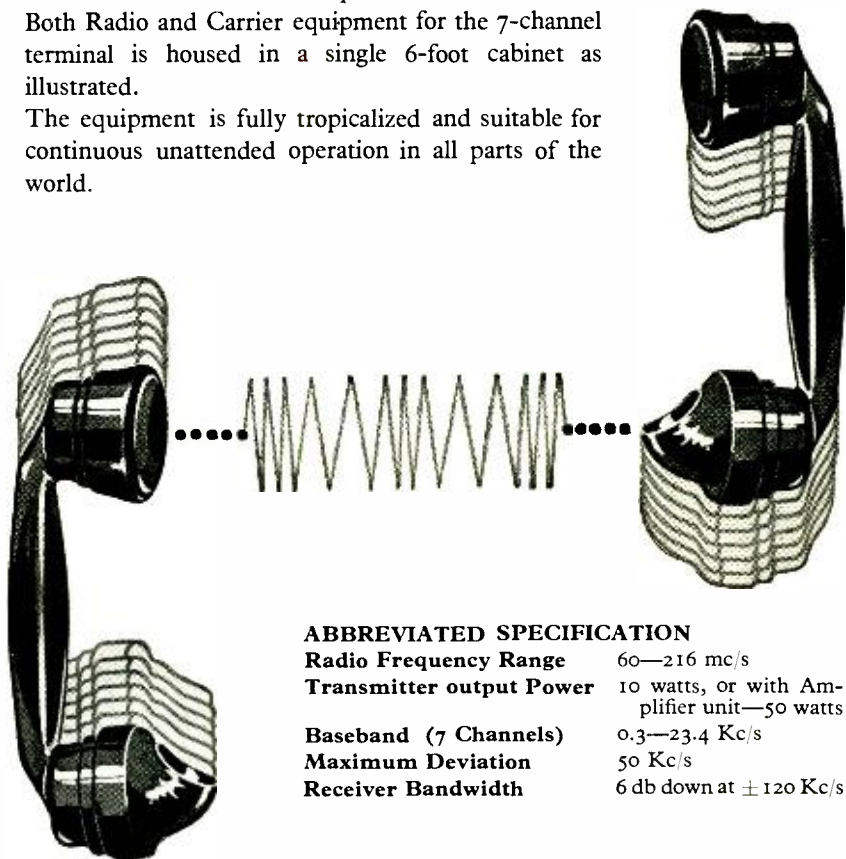

ABBREVIATED SPECIFICATION

Radio Frequency Range	60—216 mc/s
Transmitter output Power	10 watts, or with Amplifier unit—50 watts
Baseband (7 Channels)	0.3—23.4 Kc/s
Maximum Deviation	50 Kc/s
Receiver Bandwidth	6 db down at ± 120 Kc/s



Telecommunications

CAMBRIDGE ENGLAND



Pye New Zealand Ltd Auckland C.I., New Zealand	Pye Canada Ltd Ajax, Canada	Pye-Electronic Pty., Ltd. Melbourne, Australia	Pye Ireland, Ltd. Dublin, Eire
Pye Radio & Television (Pty) Ltd Johannesburg South Africa	Pye Limited Mexico City	Pye Limited Tucuman 829 Buenos Aires	Pye Limited 5th Avenue Building 200, 5th Avenue, New York
PYE LIMITED . . . CAMBRIDGE . . . ENGLAND			

for absolute reliability in

RAYDIST ultra-sensitive electronic tracking systems

THE
LOGICAL
CHOICE
WAS



This power supply, shown with the Raydist mobile electronic tracking system, is typical of the use of CHICAGO transformers in Raydist equipment.

CHICAGO the World's Toughest TRANSFORMERS

Raydist, designed and built by the Hastings Instrument Company, Inc., of Hampton, Virginia, is a remarkably precise and sensitive electronic radio location system. Raydist systems are used for air and marine navigation tracking, marine geophysical surveying, chartmaking, meteorological studies and a host of applications requiring infinitely accurate tracking and plotting.

Because Raydist precision performance is dependent upon the quality of the components used, Hastings specifies and uses CHICAGO MIL-T-27 hermetically sealed transformers.

Wherever absolute reliability and optimum precision are essential, you'll find CHICAGO, truly the world's toughest transformers.



CHICAGO MIL-T-27
Sealed-in-Steel Transformer

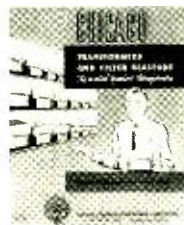

FREE: CHICAGO Catalog CT 554, listing over 500 Sealed-in-Steel transformers. Available from your parts distributor.



**CHICAGO STANDARD
TRANSFORMER CORPORATION**
Addison and Elston • Chicago 18, Illinois

EXPORT SALES:
Robura Agencies, Inc.
431 Greenwich St.
New York 13, N.Y.

**RADIO-ELECTRONIC
Engineering**

Reg. U.S. Pat. Off.

INCLUDING

TV & RADIO & Communication
ENGINEERING Engineering

Edited by H. S. RENNE
and the Radio & Television News Staff

VOLUME 24

NUMBER 5

MAY, 1954

Editor and Asst. Publisher

OLIVER READ, D. Sc.

Managing Editor

WM. A. STOCKLIN, B. S.

Technical Editor

H. S. RENNE, M. S.

Assistant Editor

M. C. MAGNA

Art Editor

FRANK SAYLES

Draftsmen

ALBERT A. GANS
JOSEPH A. GOLANEK

Advertising Director

L. L. OSTEN

Advertising Manager

TED SUITO

Western Adv. Manager

JOHN E. PAYNE

ZIFF-DAVIS PUBLISHING COMPANY

WILLIAM B. ZIFF (1898-1953) FOUNDER

Editorial and Executive Offices

366 Madison Ave., New York 17, N. Y.

President

B. G. DAVIS

Vice-Presidents

H. J. MORGANROTH
M. H. FROELICH

Secretary-Treasurer

G. E. CARNEY

Circulation Manager

M. MICHAELSON

BRANCH OFFICES

CHICAGO (1): 64 E. Lake St.
LOS ANGELES (14): 900 Wilshire Blvd.

RADIO-ELECTRONIC ENGINEERING is published each month as a separate publication and is available by subscription only when purchased with a subscription to RADIO & TELEVISION NEWS.

(Average Paid Circulation Over 28,000)

Copyright 1955 by Ziff-Davis Publishing Company
(All Rights Reserved)

RADIO-ELECTRONIC ENGINEERING is published monthly by Ziff-Davis Publishing Company, William B. Ziff, Chairman of the Board (1946-1953) at 64 E. Lake St., Chicago 1, Ill. Entered as second-class matter March 29, 1954 at the post office, Chicago, Ill. SUBSCRIPTIONS: Subscribers to Radio-Electronic Engineering automatically receive Radio & Television News. RATES: one year U. S. and possessions, and Canada \$8.00; Pan-American Union countries \$6.50; all other foreign countries \$7.00; SUBSCRIPTION SERVICE: All communications concerning subscriptions should be addressed to Circulation Dept., 64 E. Lake St., Chicago 1, Ill. Subscribers should allow at least four weeks for change of address.



A red-nosed Fokker slowly spun to earth



AT 4:35 P.M., on October 30, 1918, a lone Spad biplane, marked with the symbol of the "Hat-in-the-Ring" Squadron, hawked down through the quiet skies over Grande Pré. Seconds later, a twenty-round burst of its guns smashed full into the center of a low-flying Fokker and sent the German plane swirling earthward like an autumn leaf.

The C.O. of the squadron, Captain Eddie Rickenbacker, had downed his last enemy plane of the war, setting a record for aerial combat never equaled: 26 victories in 7 months. It made him the American ace of aces.

A year earlier, his mother had written, "fly slowly and close to the ground"; but it was advice that Eddie Rickenbacker—like many of his fellow Americans—has never been able to take. His calculating courage, ingenuity and drive are typical of our greatest asset.

Which is not simply factories, farms, or gold—but millions of a particular kind of people called Americans. And it is these people—people like yourself—who stand behind what is probably the world's finest investment: U. S. Series E Savings Bonds.

To buy United States Series E Savings Bonds is to join them in their proud confidence of their country and its future—and to protect your own personal security as well.

★ ★ ★

It's actually easy to save money—when you buy United States Series E Savings Bonds through the automatic Payroll Savings Plan where you work! You just sign an application at your pay office; after that your saving is done *for* you. And the Bonds you receive will pay you interest at the rate of 3% per year, compounded semiannually, for as long as 19 years and 8 months if you wish! Sign up today! Or, if you're self-employed, invest in Bonds regularly where you bank.

Safe as America—U. S. Savings Bonds

The U. S. Government does not pay for this advertisement. It is donated by this publication in cooperation with the Advertising Council and the Magazine Publishers of America.



ENGINEERS and SCIENTISTS...

As RCA moves ahead, YOU can do the same!

RCA expansion opens career opportunities for you in:

AVIATION ELECTRONICS
ELECTRON TUBES
COMPUTERS
MISSILE GUIDANCE
RADIO SYSTEMS

These are permanent positions, complete with all the advantages of a well-rounded, liberal benefits program. Check the chart for specific opportunities...

FIELDS OF ENGINEERING ACTIVITY	TYPE OF DEGREE AND YEARS OF EXPERIENCE PREFERRED											
	Electrical Engineers			Mechanical Engineers			Physical Science			Chemistry Ceramics Glass Technology Metallurgy		
	1-2	2-3	4+	1-2	2-3	4+	1-2	2-3	4+	1-2	2-3	4+
SYSTEMS <i>(Integration of theory, equipments, and environment to create and optimize major electronic concepts.)</i>												
AIRBORNE FIRE CONTROL			W							W		
DIGITAL DATA HANDLING DEVICES			C			C				C		
MISSILE GUIDANCE			M			M				M		
INERTIAL NAVIGATION			M			M				M		
COMMUNICATIONS			C O F							C O F		
		F						F				
DESIGN • DEVELOPMENT												
COLOR TV TUBES —Electron Optics—Instrumental Analysis—Solid States (Phosphors, High Temperature Phenomena, Photo Sensitive Materials and Glass to Metal Sealing)	L	L	L	L	L	L	L	L		L	L	L
RECEIVING TUBES —Circuitry—Life Test and Rating—Tube Testing—Thermionic Emission	H	H	H		H	H		H			H	H
MICROWAVE TUBES —Tube Development and Manufacture (Traveling Wave—Backward Wave)		H	H	H				H	H		H	H
GAS, POWER AND PHOTO TUBES —Photo Sensitive Devices—Glass to Metal Sealing	L	L	L	L	L			L	L		L	L
AVIATION ELECTRONICS —Radar—Computers—Servo Mechanisms—Shock and Vibration—Circuitry—Remote Control—Heat Transfer—Sub-Miniaturization—Automatic Flight—Design for Automation—Transistorization			M C F			M C F				M C F		
		F	F		F	F		F	F		F	F
RADAR —Circuitry—Antenna Design—Servo Systems—Gear Trains—Intricate Mechanisms—Fire Control			M C F			M C F				M C F		
		F	F		F	F		F	F		F	F
COMPUTERS —Systems—Advanced Development—Circuitry—Assembly Design—Mechanisms—Programming	C	C	M C F	C	C	M C F	C	C	M C F			
		F	F		F	F		F	F		F	F
COMMUNICATIONS —Microwave—Aviation—Specialized Military Systems			M C F			M C F				M C F		
		F	F		F	F		F	F		F	F
RADIO SYSTEMS —HF-VHF—Microwave—Propagation Analysis—Telephone, Telegraph Terminal Equipment		O	O F		O	O F		O	O F		O	O F
MISSILE GUIDANCE —Systems Planning and Design—Radar—Fire Control—Shock Problems—Servo Mechanisms		F	M F		F	M F		F	M F		F	M F
		F	F		F	F		F	F		F	F
COMPONENTS —Transformers—Coils—TV Deflection Yokes (Color or Monochrome)—Resistors		C	C		C	C		C	C		C	C
MACHINE DESIGN Mech. and Elec.—Automatic or Semi-Automatic Machines		H	H		H	H		H	H		H	H

Location Code
C—Camden, N. J.—in Greater Philadelphia near many suburban communities.
F—Florida—on east central coast.
H—Harrison, N. J.—just 18 minutes from downtown New York.

L—Lancaster, Pa.—about an hour's drive west of Philadelphia.
M—Moorestown, N. J.—quiet, attractive community close to Phila.
O—Overseas—domestic and overseas locations.
W—Waltham, Mass.—near the cultural center of Boston.

Please send resume of education and experience, with location preferred, to:

Mr. John R. Weld, Employment Manager
 Dept. C-4E, Radio Corporation of America
 30 Rockefeller Plaza
 New York 20, N. Y.



RADIO CORPORATION OF AMERICA

Copyright 1955 Radio Corporation of America

"PROGRESS LINE" RECEIVER DESIGN

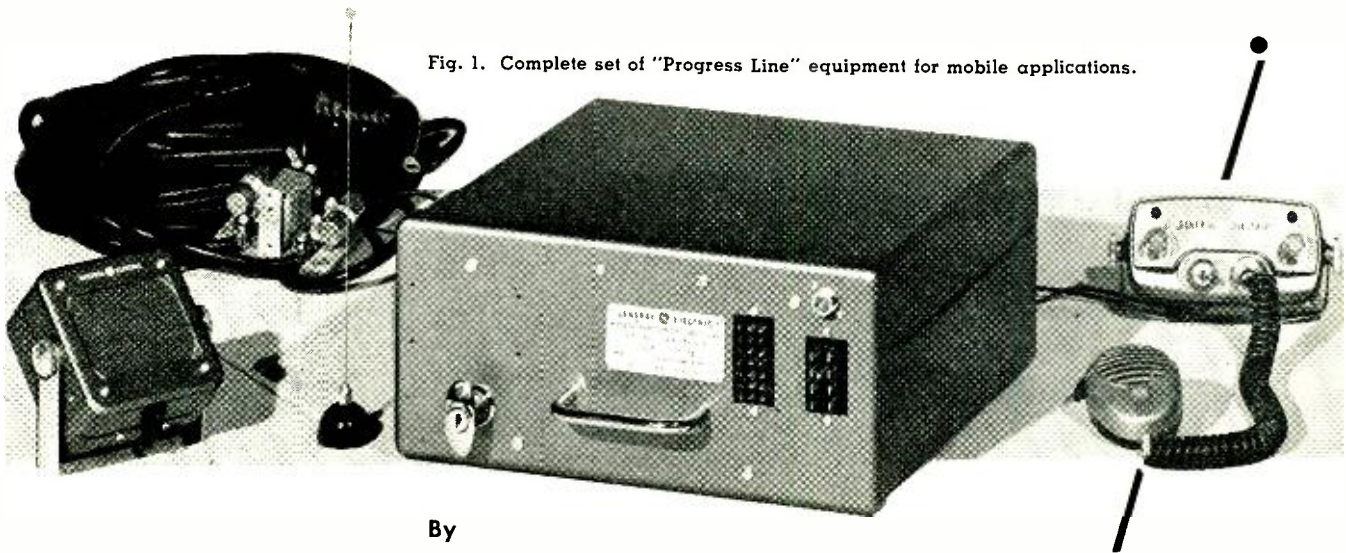

Fig. 1. Complete set of "Progress Line" equipment for mobile applications.

By

J. A. McCORMICK

General Electric Company

THE RAPIDLY expanding use of two-way radio since the last war is a real challenge to the equipment designer and manufacturer to provide equipment capable of delivering good communication under increasingly crowded spectrum conditions. In addition to the severe technical problems imposed by such crowding, the manufacturer is called upon to supply an almost infinite variety of equipment to meet the general and special requirements of the many classes of users licensed in the land-mobile services.

To fulfill these industry requirements most effectively, a fully integrated family of equipment has been developed which establishes new standards of performance and versatility. The new line has been aptly titled the "Progress Line" since it does, in fact, represent demonstrable progress in the state of the art.

A mobile or land station unit in these services consists basically of a transmitter, a receiver, and a power supply. Great flexibility has been provided in the "Progress Line" by designing each of these components so that they are completely interchangeable with other units of their type. Figure 1 is a photograph of a complete set of equipment for mobile applications. Figure 2 shows the receiver chassis about to be installed in the rack-mounting type cabinet for mobile service. Transmitter, receiver and power supply chassis are each secured to the rack channels by four bolts, with the electrical connections completed by multiconductor cables terminated in standard plugs and receptacles.

Not the least important of the three components is the receiver. It is responsible in large measure for the remark-

ably good system performance now available to land-mobile users. It is called upon to reproduce signals as weak as $0.3 \mu\text{v}$. in the presence of adjacent-channel signals many thousands of times stronger—a situation unique in all the radio services.

Basic Characteristics

Receivers have been designed for both the low band (25-50 mc.) and the high band (152-174 mc.). They have the following over-all characteristics:

1. All receivers are physically interchangeable by means of quick disconnects whether they be for high or low band, mobile or station use. This high order of interchangeability makes it unnecessary to tie up a vehicle for radio service. It minimizes the dollar investment in spare equipment because a single receiver can replace any other receiver in the system, station or mobile, without the need to replace the complete equipment, i.e., transmitter, receiver and power supply.
2. Receivers in mobile use can be serviced on the bench by using the standard station-type a.c. power supply, thus eliminating the need for storage batteries or costly rectifier-type power supplies.
3. All of the new receivers will operate

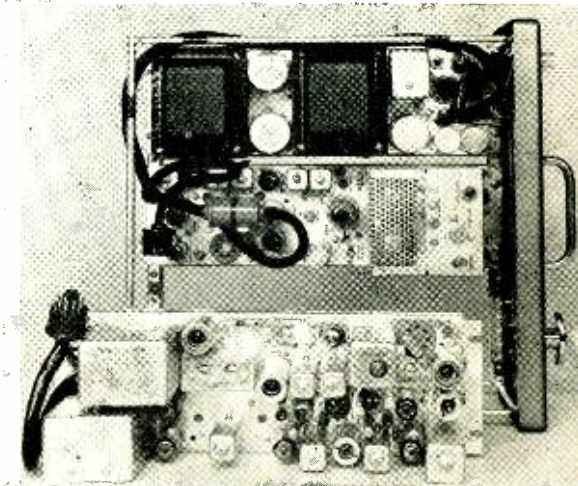
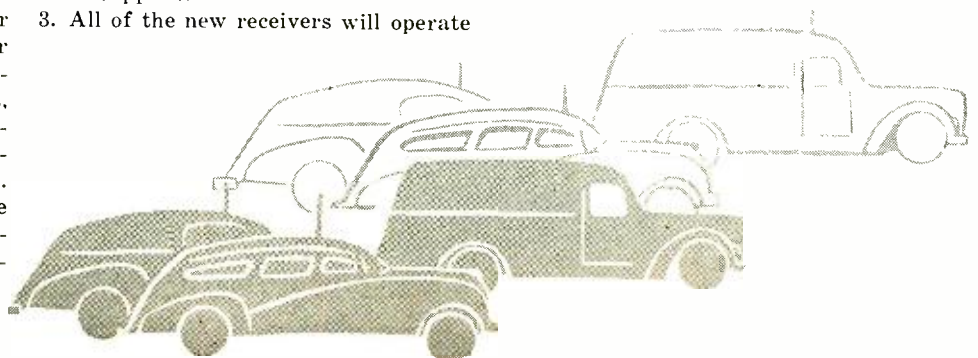

Fig. 2. Receiver chassis ready to be installed in rack-mounting type cabinet for mobile service.

Complete redesign of equipment for the 25-50 and 152-174 mc. bands has led to greater receiver sensitivity and improved receiver selectivity.



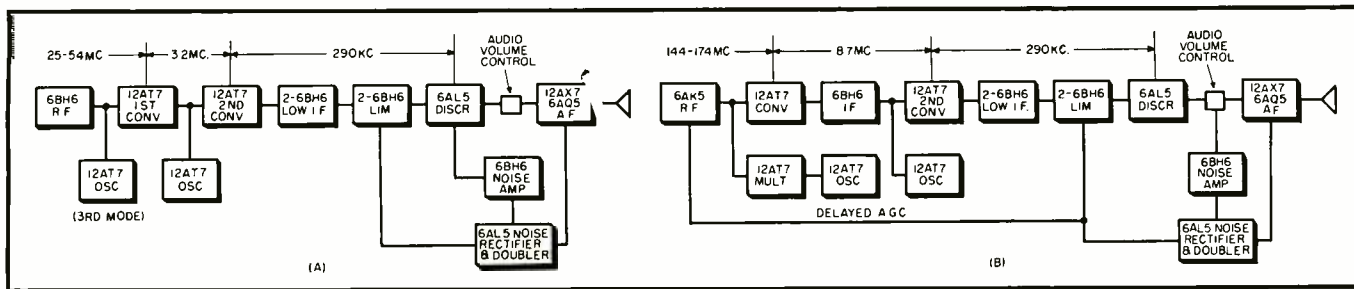

Fig. 3. Block diagrams of (A) the 25-50 mc. receiver and (B) the 152-174 mc. receiver show their similarity.

from either a 6/12 volt d.c. or a 117-volt a.c. power supply without modification of any kind.

- Multiple-channel operation can be provided for up to four frequencies within a total spread not exceeding 0.4% of the operating frequency.
- The receivers are available for wide-band or narrow-band operation, and either type can be converted to the other in the field easily and inexpensively. In installations where high selectivity is not immediately essential, extra-wide passband can be provided by omitting or bypassing some of the selectivity-determining elements. At any future time that protection against adjacent channel signals might become necessary, these selectivity elements can be reinserted.

Block diagrams of the receivers for the two frequency bands are shown in Figs. 3A and 3B. Considerable similarity between the circuits will be noted. Both are double-conversion superheterodynes with the oscillators individually crystal-controlled, which is essential in multi-frequency operation in order to center the high i.f. amplifier tuning on all channels. Both use the same size chassis, 13½" deep by 4½" wide by 5¾" high; the receivers go into the same variety of station and mobile type cabinets; and they use the same accessories and power supplies.

Front End Design

Interference from adjacent-channel stations is primarily a function of the selectivity of the low i.f. amplifier, but the fact that the front-end selectivity of a receiver determines the degree of rejection of signals 2, 3, 4 or more channels removed is often overlooked. Front-end selectivity includes both the r.f. and high i.f. amplifiers. The ratio of the bandwidth to the operating frequency in the v.h.f. bands makes it impossible to design tuned circuits with sufficient Q to provide adjacent-channel selectivity at the front end of a receiver, but this would be the ideal place to apply the selectivity if it were possible—ahead of the first tube grid. High order front-end selectivity prevents strong, off-channel signals from getting well into the receiver where they can desensitize it or develop strong intermodulation prod-

ucts. The new receivers have five high- Q tuned circuits in the r.f. amplifier, two of which are in the most important selectivity point in the set, i.e., ahead of the first r.f. grid. The preselector transformers consist of air-wound coils tuned by silver-plated, variable, air-trimmer capacitors. Use of iron cores which would necessarily lower the Q , particularly in the 150-mc. band, is avoided.

Figure 4 compares the selectivity of the antenna transformers or preselectors with that found in typical receivers in the land-mobile services. The selectivity of cavity resonators having extremely high Q is also shown to the same scale for comparison purposes. It can be seen that substantial improvement has been realized in the "front end" department.

Between the r.f. tube and the converter, each receiver has a triple-tuned transformer. Here again, the high-band receiver uses air-wound coils and ceramic trimmers to provide the highest possible Q . The low-band receiver employs a combination of ceramic trimmers and adjustable iron cores which provide very high Q in addition to covering the entire 30-50 mc. portion of the band in a single transformer.

Two r.f. stages have been in general use in high-band receivers primarily for selectivity purposes—to obtain high image response ratios—rather than for gain requirements. In the new high-band receiver, skillful design of the single r.f. stage has made a second stage unnecessary. The gain is more than sufficient to override first converter noise, and the selectivity provides better than 100-db image rejection. Delayed a.g.c. is provided to reduce high level inter-

modulation interference; the a.g.c. bias is delayed so that full r.f. gain is available for the reception of threshold signals.

Notwithstanding the exceptional front-end performance, specific cases of interference will continue to arise due to the operation of two or more stations in close proximity to each other either geographically or in frequency, or both. Often it is economically advantageous to operate four or more antennas on one tower with the associated transmitters and receivers in a house at the base of the tower. Unless the frequencies are well spaced, i.e., of the order of 3% or more between each pair, additional r.f. selectivity is often required to protect each receiver from the strong transmitter signals in order that it may respond to the very weak signals from distant mobile units. Cavity resonators are often used for this purpose, but they are rather large physically, quite costly, and they introduce from ½ to 3 db insertion loss.

For the past several years, the receiver design group at G-E has been increasing effective r.f. selectivity by filtering out the specific frequency or frequencies that cause the interference. A series resonant crystal for each frequency it is desired to suppress is placed in shunt with one or more of the r.f. tuned circuits. Then each circuit is retuned to compensate for the capacitance of the crystal holder. This technique has been used to take out interference due to adjacent channel stations only 20 kc. away! In order to utilize it more readily in the future, "Progress Line" antenna transformer shields are drilled to permit easy installation of a crystal and holder, so that a filter crystal resonant to the offending frequency can be plugged into the circuit at will.

Iron-core tuning is used in the high i.f. amplifiers of both the high-band and low-band receivers. The high-band high i.f. operates at 8.7 mc. and consists of a four-coil transformer and a 6BH6 tube, followed by a two-coil transformer into the grid of the second converter. On the other hand, the low-band high i.f. consists of a 3.2-mc. four-coil transformer between the first and second converter; at the lower frequency of this amplifier, the tube gain provided in the

Fig. 4. Selectivity characteristics of antenna transformers compared to cavity resonators and to typical 1954 receivers.

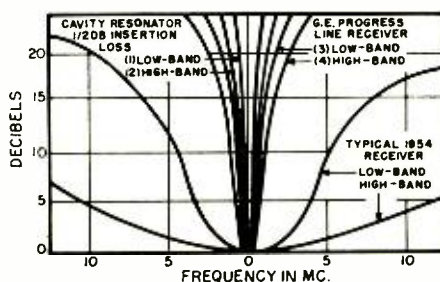

high-band receiver is neither required nor desired. The combination of selectivity and the right degree of gain in both of these amplifiers makes it extremely difficult for off-channel signals to desensitize the second converter in either receiver.

First Conversion Oscillator

An extremely important consideration in communication receiver development is the choice of circuit and design of the first conversion oscillator, because of its great importance in determining the over-all frequency stability of a receiver. Present-day crystals are remarkably stable devices provided that they are used in circuits which do not detract from their inherent stability. Tank inductances, wiring, stray capacitances and all other parts of the oscillator circuit must be controlled so that they do not impair the frequency stability. "Rubbering" adjustments which permit the frequency to be moved slightly up or down to exact system frequency must be properly applied so that they do not have too much range or cause drift in the oscillator frequency. The practical fact is that crystal stability is no better than the circuit or the environment in which it is used.

Much has been written about the use of heated crystals in the land-mobile services, but the additional stability provided by temperature control can often be offset 10 to 1 or more by circuit instability. Frequently, crystal ovens accomplish no more than to compensate in part for these other sources of error. Excellent mechanical stability of all the parts making up the oscillator circuit is essential. In a 450-mc. receiver, for example, where frequency stability is 3 to 1 more critical than in the 150-mc. band and 9 to 1 more critical than in the 50-mc. range on a percentage

basis, it has been found necessary to secure the oscillator tube and its shield rigidly in place so that the frequency cannot be shifted by mechanical movement of tube or shield.

Mode crystals in which the output frequency is some multiple of the fundamental mode of vibration of the crystal—usually the third—have proven extremely stable in mobile service provided that the plate tank is resonated slightly higher in frequency than is indicated by a peak-reading tuning meter, and provided further that no "rubbering" adjustment is incorporated. Wherever rubbering is necessary to "zero" the operating frequency, the use of a fundamental frequency crystal has been found to be much more satisfactory than a mode crystal, even though the fundamental crystal requires a multiplier chain to reach the desired injection frequency.

The new high-band receiver employs a fundamental frequency crystal with the Miller circuit. Crystal frequency is in the 12-mc. range and the oscillator output is multiplied twelve times to reach the injection frequency. A small ceramic trimmer, in shunt with the crystal, affords ample "rubbering" range to permit adjusting the oscillator for exact system frequency.

The low-band receiver employs a third-mode crystal in the Miller circuit, with rubbering provided by a ceramic trimmer on the second oscillator in the receiver. Two-frequency operation is optional on any standard receiver chassis. Additional channels can be furnished in an "option" chassis which is mounted directly adjoining the receiver chassis and essentially becomes a part of it.

Low-I.F. Amplifier

That part of each receiver wherein the major portion of the gain and selectivity resides is the low-i.f. amplifier. The

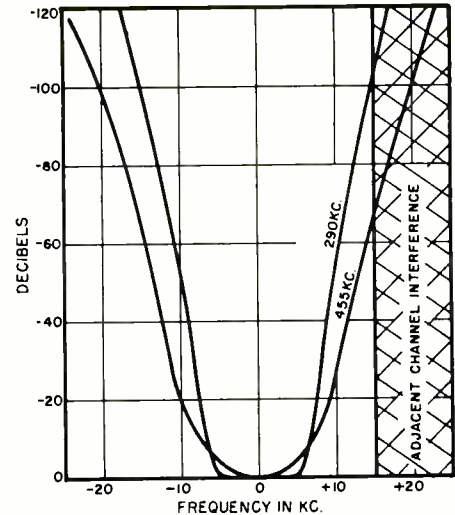

Fig. 6. Comparison of selectivity of 455-kc. i.f. amplifier with 290-kc. amplifier, each using 12 tuned circuits.

selectivity-determining element is a 6-coil 290-kc. transformer in the high-band receiver and two such transformers in the low-band receiver. Space is provided in the high-band set for the possible future addition of a second 6-coil transformer, but this will not be beneficial unless the present 60-kc. channels are split into either 15-kc. or 20-kc. channels. If the channels are split into two 30-kc. channels, the single 6-coil transformer will continue to provide local area adjacent-channel selectivity. The 6-coil i.f. transformer has been chosen as the ideal unit for achieving the desired gain and selectivity.

The high impedance of the tuned circuits makes them ideal for voltage amplification; they can be designed to operate equally well with triodes or pentodes. They can be tuned quickly and easily in the factory or in the field because all circuits are tuned to center frequency; there is no "stagger" tuning. After assembly, each of the six circuits in each transformer is quickly tuned to exact resonance by means of the "peak and dip" tuning method. The response curve is then inspected on an oscilloscope. Inasmuch as each circuit is tuned to center frequency, each circuit is resistive at resonance and loads the adjacent tuned circuits, thereby providing the broad response at the nose of the selectivity curve for full passband at threshold signal levels. Conversely, at frequencies off resonance, the tuned circuits become reactive and present very low impedance to the off-frequency signals, effectively bypassing or short-circuiting them. This characteristic results in very steep side walls which continue nearly perpendicular even beyond 140 db above the quieting sensitivity level.

Bandwidth of the amplifier is determined by the degree of coupling between the coils; therefore, by simple ad-

(Continued on page 26)

Fig. 5. Disassembled view of 6-coil i.f. transformer showing individual shielding.

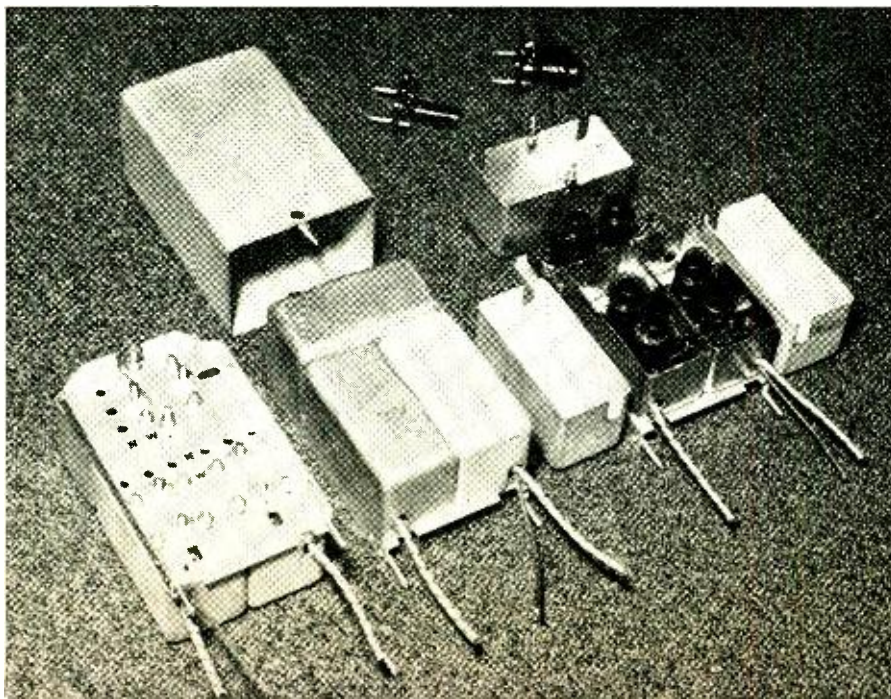

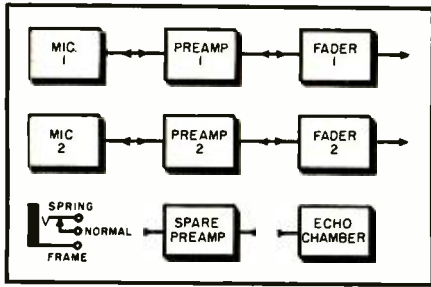

Fig. 1. Simplified diagram of a typical audio system with details of a single jack.

Audio-type jacks and panels have proved to be highly satisfactory for video patching. Effects of crosstalk and stray capacity on picture quality are negligible.

By

R. D. CHIPP

Du Mont Television Network

A VIDEO PATCHING SYSTEM

IN ANY TV station, some sort of a video patching system is a necessity.

The system now in use at the *Du Mont* Telecentre in New York is extremely simple, effective, and gives highly satisfactory performance. It is based on the type of audio patching used by broadcasters for years.

Before describing the details of this video patching system, a brief review of audio patching is in order. The two major advantages of the audio system are (1) operational flexibility and (2) instant availability of spare equipment

Fig. 2. Screw-type coaxial fittings such as were employed in many of the earlier TV installations for patching purposes.

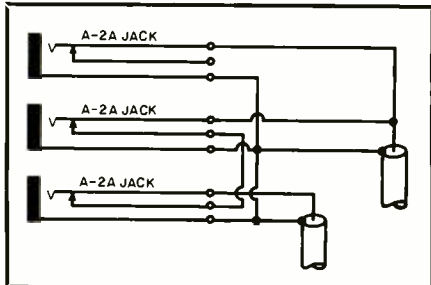
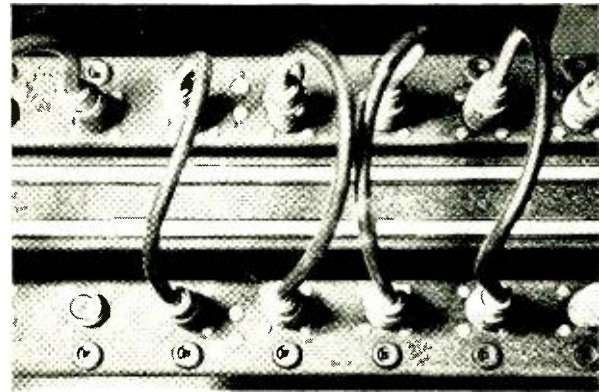
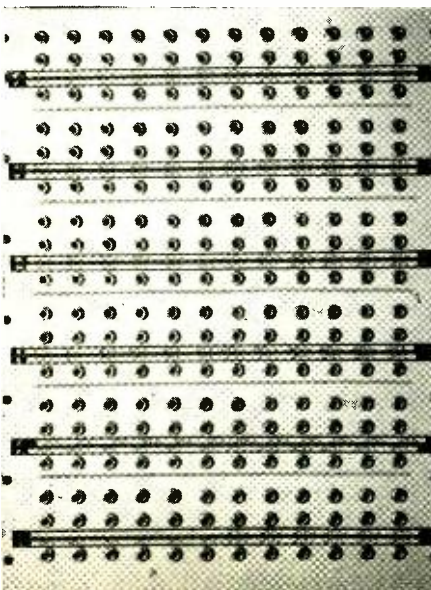

Fig. 3. Schematic diagram of the video patching system using audio-type jacks.

Fig. 4. Typical *Du Mont* video patch panel.



and circuits. Figure 1 is a simplified schematic of a typical circuit showing microphones normalled through preamplifiers to faders. In the lower left-hand corner is a detail drawing of the well-known form A arrangement of contacts on a single jack. A spare preamplifier may be substituted instantly in an emergency by means of two patch cords. For operational reasons, it may be desired to have microphone #1 appear on fader #2; a single patch can accomplish this readily. Telephone filters and echo chambers can likewise be patched into any required line with ease.

Now consider the video system, which is based on equipment having single-ended outputs, and which uses coaxial cable instead of shielded pair for interconnection. Many early TV installations employed screw-type coaxial fittings (Fig. 2); later, coaxial plugs and jacks were used. Still later, in about 1946, a number of video installations were made with audio-type jacks and plugs. At the time, this was considered a stopgap pending the development and procurement of new coaxial jacks. Then Station WGN, the *Du Mont* affiliate in Chicago, completed a studio installation of considerable size in which audio jacks were used for video.

The success of WGN's installation prompted the consideration of this type

of patch system for a somewhat larger and more complex installation, which involved approximately 3500 connections for video and 1000 connections for sync and drive pulses. A mock-up panel was constructed, and tests were made for crosstalk, capacity effects, etc. As a result of these tests, it was concluded that a TV plant could operate satisfactorily with a patching system based on the use of jacks and plugs originally developed for audio applications. Use of such a system offered the same two advantages, operational flexibility and instant availability of spare equipment and circuits, plus substantial cost reduction.

Design Details

Components of this video patching system are standard items: a Mallory A-2A jack and a PL-55 plug. These components are assembled in a basic unit, shown schematically in Fig. 3. Note the arrangement of three jacks, one above the other, to form an input, output, and multiple combination. In a few instances, extra contacts are provided for tally light circuits in master control.

Figure 4 shows a video patch panel in a typical studio at the *Du Mont* Telecentre. The jacks are mounted in groups of three vertically and 12 horizontally. Each jack is electrically isolated from the panel with the ground connection carried through on the coaxial cable outer conductor only.

*This article is based on a paper presented at the National Association of Radio and Television Broadcasters which was held in Chicago in May, 1954.

In Fig. 5 is a simplified schematic of a portion of the video system. Note that during normal operation camera 1 feeds position 1 of the switching amplifier, which in turn feeds a video distribution amplifier. Likewise, camera 2 feeds position 2 of the mixer. As in the case of the audio system, spare units can be readily patched in, and circuit routing can be changed quickly to accommodate nearly any operational requirement.

Figure 6 is a rear view of one of the patch panels, and shows the wiring detail. It is important that this wiring be carefully done. The connection of RG-11/U or RG-59/U cable to the A-2A jack is relatively simple provided that proper instructions are followed. The procedure below has been found to be very satisfactory.

For the RG-11/U cable, there should be 1/2" of bare wire, 1/2" of polystyrene, and then 1" of bare braid. The outer braid is twisted into the form of a wire and tinned, thus adding support to the cable connection.

When making up patch cords of RG-59/U cable, the procedure is slightly different. The cable is prepared in such a manner as to provide 3/8" of bare wire, 3/8" of polystyrene, and 3/8" of bare braid. Shoulders on the plugs are pretinned, and each plug forced onto the cable until about 1/4" of rubber has entered the shoulder. The braid that is showing in the plug cavity is folded back and soldered to the shoulder, care being taken to prevent the polystyrene from melting. After trimming up the connection and removing the rough edges, a small lug is soldered to the center conductor and connected to the tip of the PL-55 plug.

It has been found that there are definite time and cost advantages in the fabrication and wiring of patch panels and patch cords in this manner.

Performance

Test results are illustrated in Figs. 7 through 9. First, the system was tested for crosstalk by applying a standard 4-volt horizontal drive signal to a regular studio line, and measuring the amplitude of the signal on an adjacent jack. Figure 9 shows oscillograph pictures of the drive signal (left) and the crosstalk signal (second from left), measured with a gain of 10 in the Y-axis amplifier.

The difference between the two signals is 44 db.

On the next test, a 4-volt blanking pulse was fed from a sync generator through a set of jacks to a sync distribution amplifier and sync switch, thence to a second set of jacks and a second sync distribution amplifier, and finally to a third set of jacks and a terminated oscillograph. Pictures in Fig. 9 (second from right, and right) give the input and output signals respectively.

Then a video sweep generator output was fed through a system representing unusual conditions. Figure 7 shows the input, with an 8.0-mc. marker, and Fig. 8 shows the sweep after it has been looped through a double set of jacks and a double run of cable between studio and master control.

Conclusion

A standard panel of 36 coaxial jacks, which includes 12 inputs, 12 outputs, and 12 multiples, complete with coaxial bridging plugs and five coaxial patch cords, costs approximately \$550 when installed at current labor rates. A similar panel made up of 36 audio jacks, including five patch cords, costs about \$165. In a TV plant the size of the *Du Mont* Telecentre, it has been estimated that a saving of \$45,000 can be effected.

In deciding upon a video system, the theoretical importance of unbroken continuity in a video frequency circuit should be weighed against the advantages of a system that permits normalizing. Final choice may well depend upon the size and complexity of the plant under consideration. New type coaxial jacks having normal contacts may conceivably be developed in the future.

A word about the *Du Mont* Telecentre might be in order at this time. The main building houses five live studios, the largest of which is 101' x 72' x 40'. In addition, there are two nemo studios, complete master control, film projection, and sound and picture recording facilities. Since the facilities were placed in full-time operation early in 1953, the video patching system has been used very extensively, and its record of operation justifies the faith placed in the original design.

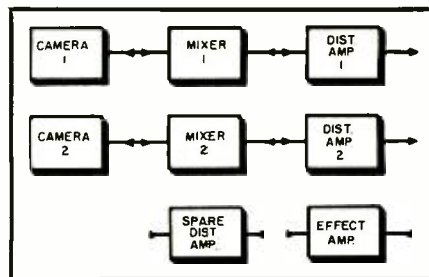

Fig. 5. Simplified block diagram of a portion of the video patching system.

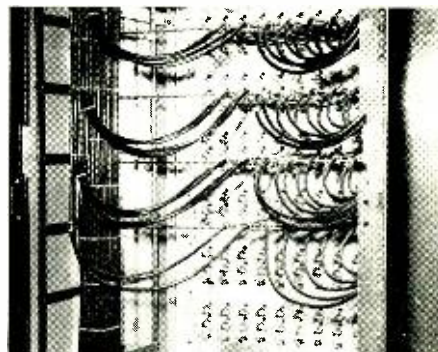

Fig. 6. Rear view of a patch panel.

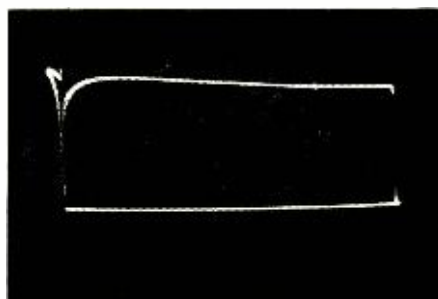

Fig. 7. Input to system from video sweep generator with 8.0-mc. marker.

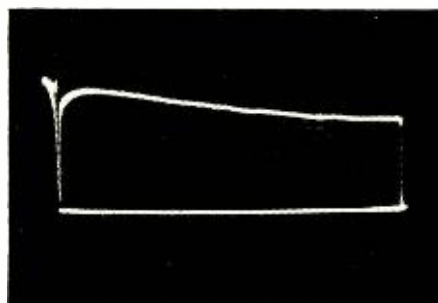
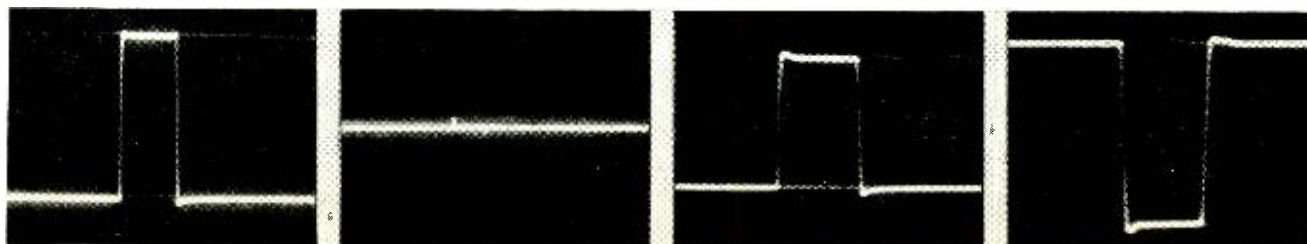

Fig. 8. Output of system after signal is looped through double set of jacks.

Fig. 9. Left to right: drive signal; crosstalk signal with gain of 10 in Y-axis amplifier; 4-volt blanking pulse from sync generator; output pulse after passing through three set of jacks in addition to other equipment.



"COMPAC" MODULES FOR ELECTRONIC PRODUCTION

Complete ACF COMPAC module, ready to be installed in a piece of electronic equipment, is compared with a miniature tube.

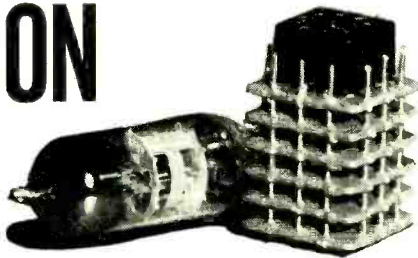

DEVELOPED by ACF Electronics, 800 N. Pitt St., Alexandria, Va., the COMPAC module is a step toward the

completely automatic production of electronic equipment. The modular design recalls NBS "Project Tinkertoy."

A decade counter that has been converted to modular design results in a unit which has better ventilating qualities, allows simplified servicing, permits easy assembly and is rugged, reliable, and of uniformly high quality.

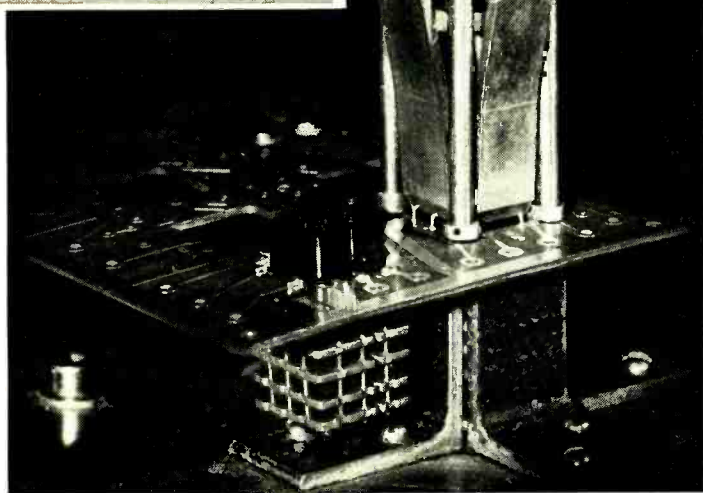
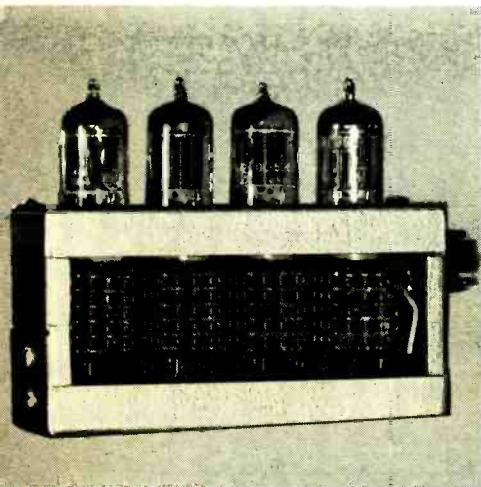

Hand-operated jig for mounting ACF COMPAC modules into printed-circuit plates. A converted drill press facilitates assembly. In a single motion, the 12 riser wires protruding through the square hole in a plate are securely clinched onto the printed pattern. After dip-soldering, the COMPAC may be considered to be an integral part of the circuit plate.

Several COMPACS are mounted on a circuit board to demonstrate a few of the wide variety of circuit combinations possible with this new technique.

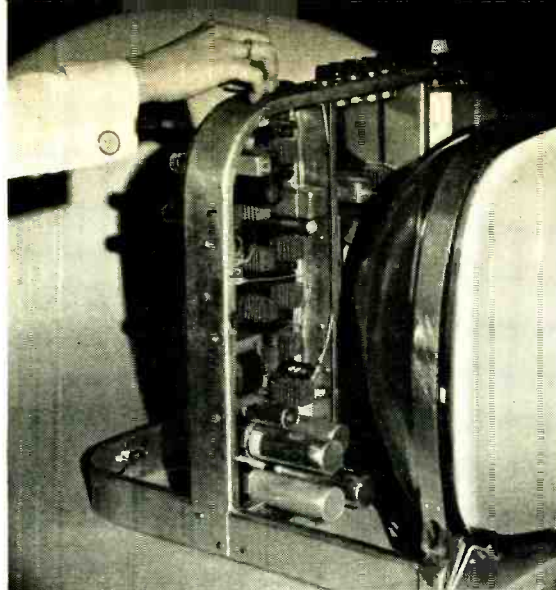

This photograph and the one below illustrate the feasibility of using modular construction in highly commercial, mass production, electronic equipment. The TV set shown here is a composite of existing television receiver designs.

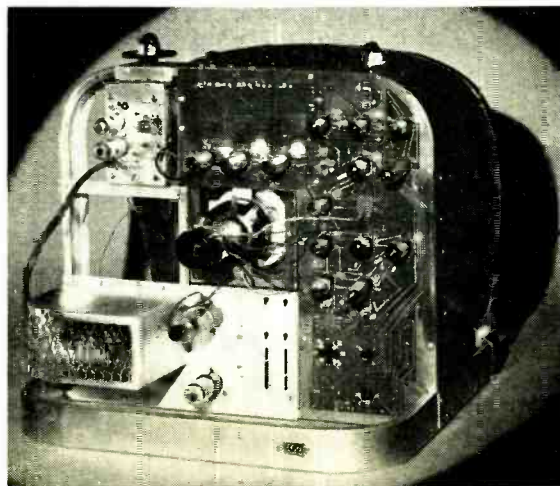

The receiver uses 195 component parts plus tuner and tube. Of these, 153 are represented in 17 COMPAC modules; others include hardware, power resistors, electrolytics, etc.

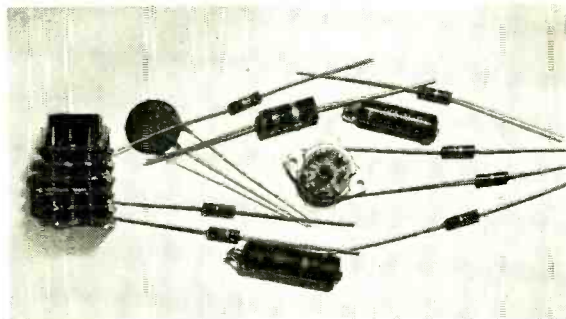

Types of component parts a typical COMPAC may incorporate. This module contains 8 resistors, 3 capacitors, a tube socket, and the associated interelement wiring.

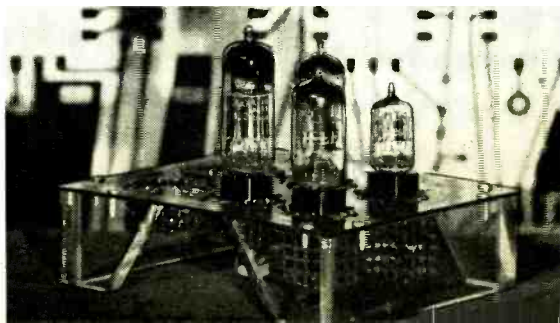

MICROWAVE TESTING WITH MILLIMICROSECOND PULSES



A. H. Method of Bell Telephone Laboratories is shown checking wave guide connections to an experimental microwave antenna.

By **A. C. BECK**

Bell Telephone Laboratories Incorporated

Very small imperfections in wave guides can be detected by a method similar in principle to the detection of targets by radar systems.

PULSES of radio energy can be caused to “bounce” off solid objects, and therefore can be very useful for radar and communication testing purposes. The principles involved are illustrated by the familiar sound echo. If one shouts and later hears an echo, the presence of the echo is evidence of a reflecting object, and the time lapse between the shout and the hearing of the echo is a measure of the object's distance away. To achieve high resolution, or discrimination between closely spaced objects, radar systems normally use very short pulses of radio energy, sometimes as short as a tenth of a microsecond.

Because discontinuities of any kind in any transmission medium usually cause reflections, pulses can be used for their location and analysis. Such discontinuities may be faults—such as poor joints in transmission lines—or necessary transitions in shape or impedance in the system. Where necessary transitions occur, best transmission results are obtained when reflections are minimized. Pulses are often utilized in measuring such effects, and it is obvious that the shorter the pulse time duration, the better the resolution that can be obtained.

Equipment has been built at the Holmdel Laboratory to generate and display short microwave pulses having a length of about 6 millimicroseconds. In the length of time energy is transmitted in one of these pulses, it travels less than 10'. Operating at a carrier frequency in the 9000-mc. range, a pulse generated by this equipment contains less than 100 cycles of r.f. energy. For such a short pulse, a very wide bandwidth is necessary; and in this equipment the pulse occupies an r.f. band about 500 mc. wide.

To achieve amplification over such a large bandwidth at microwave frequencies, traveling-wave tubes are necessary. The five 9000-mc. traveling-wave tube amplifiers developed for this purpose have a bandwidth of nearly 1000 mc. and a

gain of about 30 db. This type of amplifier is being used as the basis of a new approach to the problem of generating pulses, the principles for which were suggested by C. C. Cutler of Bell Telephone Laboratories.

Pulse-Generating System

Figure 1 is a simplified block diagram of the pulse-generating system which utilizes two traveling-wave tubes. The heart of the circuit is a feedback oscillator loop in which a traveling-wave tube, delay line, and crystal expander produce short pulses. The crystal expander causes a large power loss for a weak signal and a lower power loss for a stronger signal. If the expander were not in the loop, the gain could be adjusted to produce c.w. oscillations. When it is in the loop, however, the gain is adjusted to permit oscillations only for a strong signal, so that short pulses can be produced. The delay line, consisting of about 60' of rectangular wave guide, causes the signal to take $78\frac{1}{2}$ millimicroseconds to travel around the entire loop. This time delay is related to a synchronizing voltage, described below. Thus, the output of the oscillator to the second traveling-wave tube consists of a series of pulses that are spaced $78\frac{1}{2}$ millimicroseconds apart.

To obtain a continuous oscilloscope picture of sufficient brilliance to be useful, many pulses per second are transmitted, and the total effect is added up by superimposing the pulses in the indicator system. To make successive pulses superimpose on the receiving indicator oscilloscope, a synchronizing system must be used so that the pulse repetition rate is precisely related to the sweep repetition rate of the oscilloscope.

At the upper left of Fig. 1 is the 100-kc. oscillator which is the basis of this system. One output is used to synchronize the pulse-generating loop by doubling the synchronizing frequency seven times, so that a 12.8-mc. voltage is obtained for connection to the crystal expander. This sets the pulse repetition rate very accurately at 12.8 mc., corresponding to the delay

*This article is based on material which was presented in the December, 1954, issue of the Bell Laboratories Record.

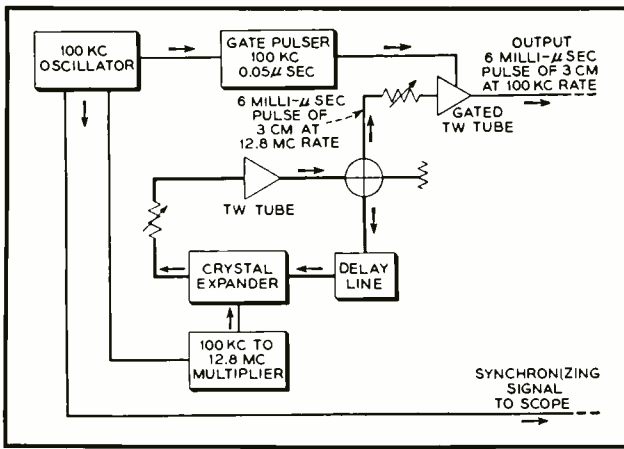

Fig. 1. Diagram of circuit used to generate millimicrosecond pulses for testing wave guides.

time of $78\frac{1}{2}$ millimicroseconds around the feedback loop. Another output of the 100-kc. oscillator is used as a synchronizing signal on the receiving oscilloscope.

The repetition rate of the pulses obtained from the loop is too high for most testing purposes since—to prevent confusion—the time between pulses must be longer than the time required for the signal to return from the farthest reflection point. Therefore, the repetition rate is reduced by means of the second traveling-wave tube amplifier. This amplifier acts as a “gating” circuit to block off most of the pulses and to select only those appearing at the desired time intervals. The tube is identical to the one in the loop. It is kept in a cutoff condition for 127 pulses and then gated to give normal amplification for the 128th pulse by using another output from the synchronizing oscillator. Thus, the output of the complete pulse-generator (Fig. 2) consists of the millimicrosecond pulses at a repetition rate of 100 kc., so that they appear every 10 microseconds. This provides enough time to receive the desired echoes before the next pulse appears.

Figure 3 is a simplified block diagram which shows the layout for the receiver and indicator equipment. Three traveling-wave tube amplifiers connected in cascade constitute the r.f. portion of the receiver. A detector and a wide-band video amplifier are used, and the output signal envelope is connected to the vertical plates of an oscilloscope. The horizontal sweep circuits for the oscilloscope have been built especially for the present application; they produce a sweep speed of the order of 6 ft./μsec., and are controlled by the 100-kc. synchronizing input from the pulse generator standard frequency oscillator.

To measure the time at which return echoes are seen, a precision phase shifter is used in the synchronizing signal path. Its function is similar to that of a range unit in a radar system. By revolving this phase shifter, it is possible to look at

Fig. 3. Block diagram of receiver and indicator equipment.

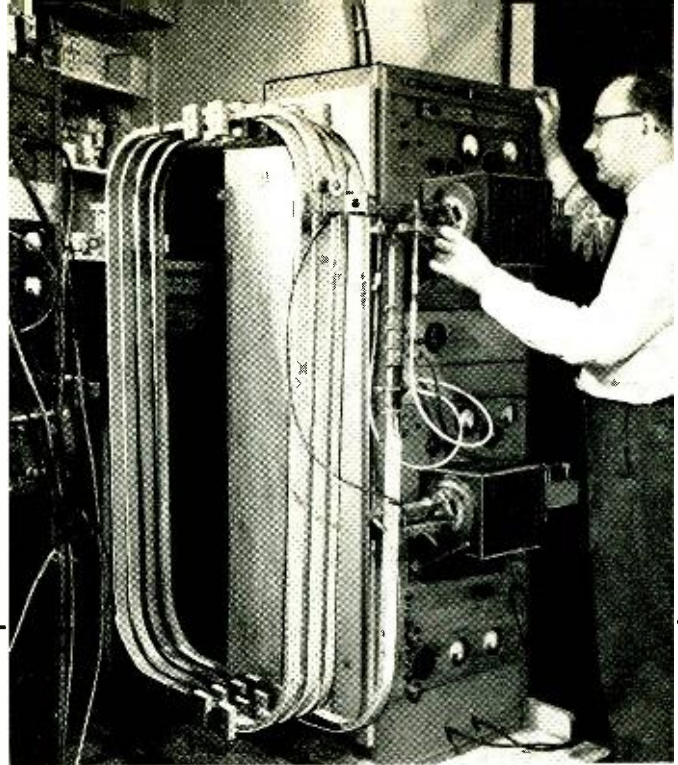
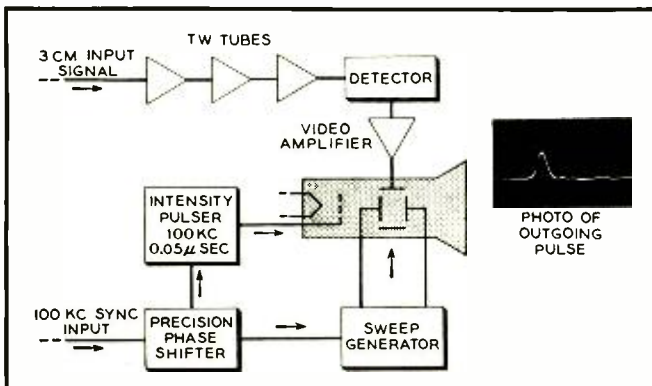

Fig. 2. The author is shown adjusting attenuator in circuit of pulse-generating equipment. Delay line is at the left.

the entire 10-μsec. interval of time between pulses on the oscilloscope. At any one time, however, only a very small part of the interval is displayed on the 5" width of the screen. The phase shifter moves the position of a pulse appearing on the scope by changing the starting time of the horizontal sweep. Accurate determination of pulse delay time is possible on the phase shifter dial, which is calibrated in millimicroseconds.

An outgoing pulse is shown in Fig. 3. The peak power output of the pulse-generating system is about 1 watt, before compression in the gated amplifier causes much pulse broadening. As the receiver noise figure is rather poor, and its bandwidth is wide, noise becomes the limiting factor on the indicator at full gain. With this equipment, echo pulses can be seen that are about 70 db below the transmitted pulse.

Figure 4 is a wave guide arrangement placed between the pulse generator and the receiver to show the resolution that can be obtained. It demonstrates the very short length of the pulses being used. The two side connections are so constructed that if they were terminated by a device which would absorb all the energy passing into the branches no energy would be transmitted to the receiver. However, a short circuit (closure at the end of a branch) placed on either side branch will send energy through the system to the receiver by reflection from one of the short circuits.

These short circuits were so placed that the one on branch

Fig. 4. Apparatus used to demonstrate resolution obtainable.

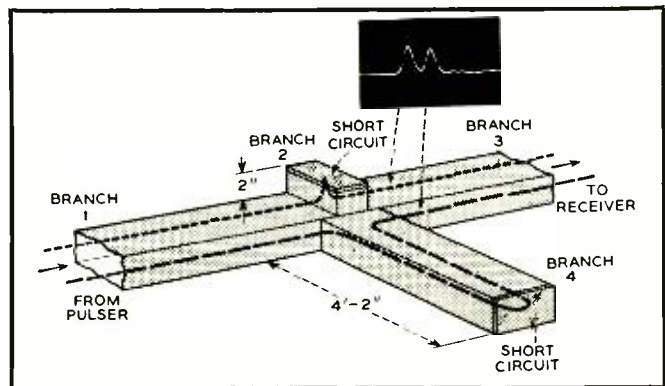

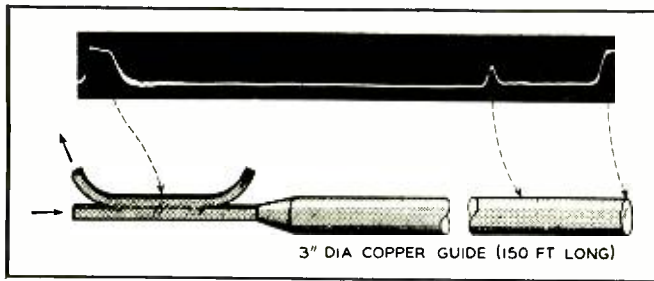
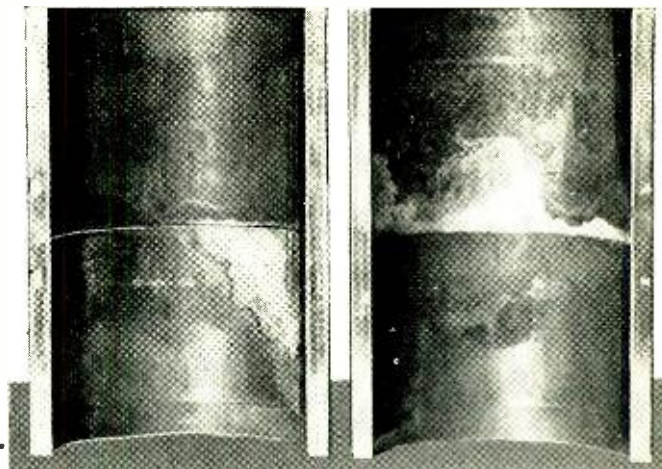

Fig. 5. Wave guide with oscilloscopic photograph showing presence of and location of defective joint.

Fig. 6. Defective joint caused by imperfect soldering was readily detected by the techniques described.



4 was 4' farther away from the junction than the one on branch 2. The pulse at the left of the oscilloscopic photograph in Fig. 4 is produced by a signal traveling from the pulser to the short circuit on branch 2, and then through to the receiver. The second pulse is produced by a signal that travels from the pulser through branch 4 to the short circuit, and then back to the receiver. While the second pulse has traveled only 8' further in the wave guide than the first pulse, it is seen to be well resolved. This would be almost equivalent to viewing two separate radar echoes from targets about 4' apart. In fact, pulses separated by a shorter distance could still be resolved. Ordinarily, such resolution can be obtained only when the pulses are nearly of the same amplitude. If the first pulse is very much stronger than the other, resolution is not as good because of the necessary recovery time from the overloaded strong pulse. However, resolution is not decreased very much by overload, and measurements can be made of a weak pulse not very far away from a strong one.

Applications

One of the applications of this equipment is in the testing of wave guide runs such as those used between antennas and the equipment in microwave repeater systems. Figure 5 shows the effect of a defective joint in 3"-diameter copper wave guide 150' long. The pulses are sent in through a directional coupler which consists of two parallel, rectangular wave guides having coupling holes in their common wall. Some of the energy returning from the round wave guide appears in the upper branch of the directional coupler and comes out at the point where the receiver is connected.

This particular round wave guide had very good soldered joints, and was thought to be electrically very smooth. The oscilloscopic photograph above the drawing, however, shows three pulse indications. At the left is an indication of the input signal as it comes from the coupler, and at the right is the pulse reflected from the short-circuited end of the wave guide. The signal between is produced by an imperfect joint in the round wave guide. By using the phase shifter, the exact location of the defect causing this echo was found and the particular joint that was at fault was then cut out of the line for inspection. Figure 6 is a photograph of the joint after the pipe had been cut in half through the middle. The wave guide is quite smooth on the inside, despite the discolored appearance of the solder, but on the left side an open crack may be seen where the solder did not run into the joint properly. This open joint caused the reflection shown on the trace.

Figure 7 illustrates the use of the equipment in the testing of wave guide and antenna installations, such as those used for microwave radio-repeater systems. This work was done in cooperation with the antenna research group at the Holm-

del Laboratory, who designed the antenna and the wave guide-to-horn transition section. A directional coupler was also used here to send energy to the transducer and wave guide, and then to the antenna. In this case, two different kinds of wave guide joints were being tested. The wave guide sections are about 10' long.

The main purpose of these tests was to measure the reflection from the transition section between the round wave guide and the square horn throat. A clamped joint in the wave guide gave the reflection following the initial overloaded pulse. A well-made threaded coupling in which the ends of the pipe butted squarely is seen to have a very much lower reflection, scarcely observable on this trace. Since there is always reflection from the aperture and upper reflector parts of this kind of an antenna, it is not possible to measure the performance of a throat transition piece in the antenna by ordinary methods. Here, the short pulses completely separated the transition-piece reflection from the other reflections, and made a measurement of its performance possible. In this particular antenna, the reflection from the transition is almost 60 db down from the incident signal, which represents very good design. As can be seen, the returned energy from the reflector and aperture is also quite low.

(Continued on page 23)

Fig. 7. Various reflections from an antenna assembly.

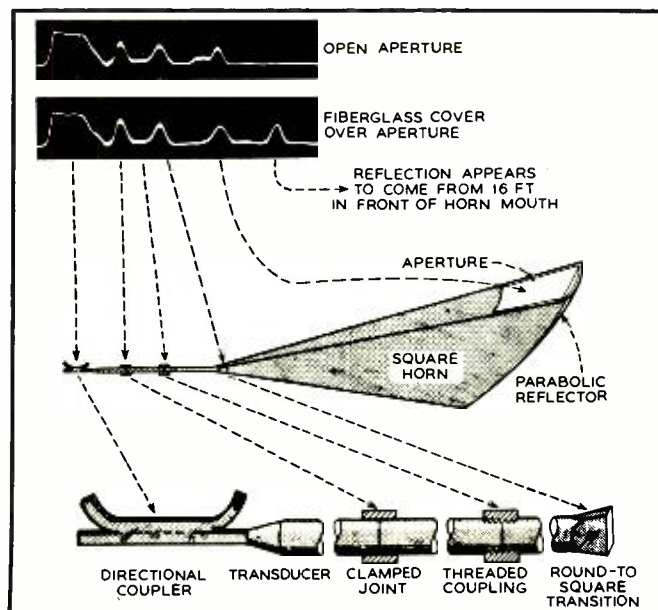

LOW-CAPACITANCE POWER SUPPLY

By

J. H. REAVES

National Bureau of Standards

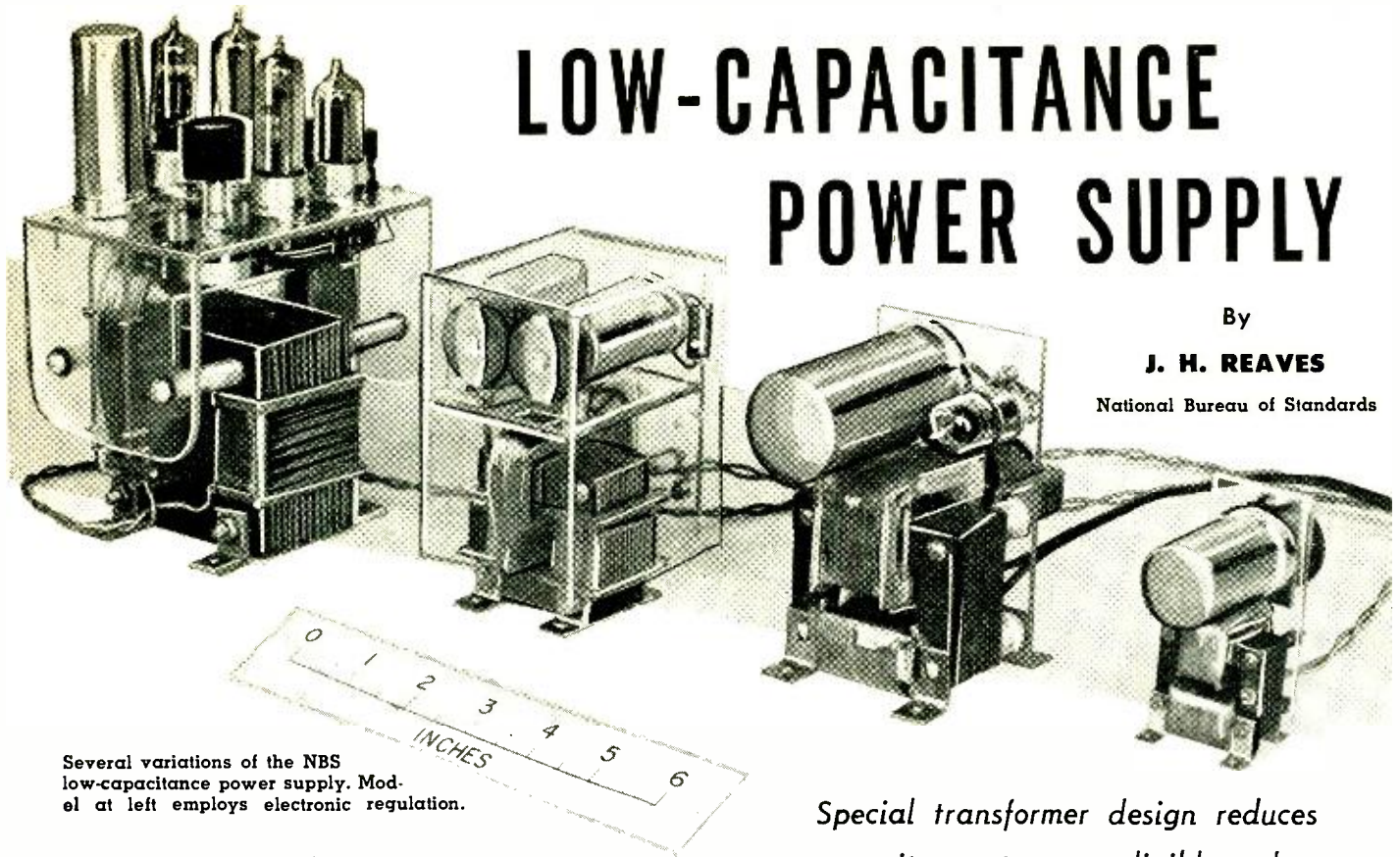

Several variations of the NBS low-capacitance power supply. Model at left employs electronic regulation.

Special transformer design reduces capacitance to a negligible value.

ESTABLISHMENT of proper d.c. operating potentials for tubes is a frequent and troublesome problem in the design of direct-coupled circuits. One solution is to use a battery in series with the signal source, but the replacement or maintenance required of a battery—especially in cases where it must supply appreciable power—is a serious disadvantage. As a conventional a.c.-operated power supply cannot be substituted in this application because of its capacitive shunting effect on the signal, a low-capacitance type of power supply has recently been developed at the National Bureau of Standards to solve the problem. The low-capacitance feature, achieved primarily by special design of the 60-cycle power transformer, enables this power supply to be employed in wide-band direct-coupled circuits requiring a power source with neither of its terminals grounded or bypassed to ground.

In the NBS supply, the shunting ca-

pacitance to ground has been reduced to such a low value as to be negligible in the circuits for which the supply is designed. The capacitance reduction has been accomplished by inserting an air gap between the core and the one or more secondary windings of the power transformer, and by compactly mounting the entire secondary circuit on an insulated chassis. Typical capacitance values obtained with this design range from 8 to 18 $\mu\text{fd.}$ and are comparable to the stray shunting capacitances of equivalent batteries. With moderately low driving impedance, this amount of capacitance has no appreciable effect at frequencies below several megacycles.

To reduce magnetic leakage resulting from the isolating air gap in the transformer, and thereby improve the voltage regulation, a split primary winding is usually employed, one-half on each side of the secondary winding. The voltage

regulation has been further improved in a 200-volt 20-ma. model of the supply by use of electronic stabilization; in this model, the output voltage varies approximately 1% from no load to full load, and over a reasonable range of line voltages.

The low-capacitance power supply is particularly useful in the laboratory as a means for easily determining the proper operating voltages for experimental circuits. In addition to the direct-coupling application, for which it is uniquely suited, it may also be used in circuits in which one terminal is grounded, though it offers no special advantages for such conventional applications.



Schematics of four applications of the NBS power supply: (A) and (B) show two methods of use in interstage coupling; (C) demonstrates use in a pentode cathode-follower circuit; (D) is a special application in a direct-coupled cathode-follower circuit.

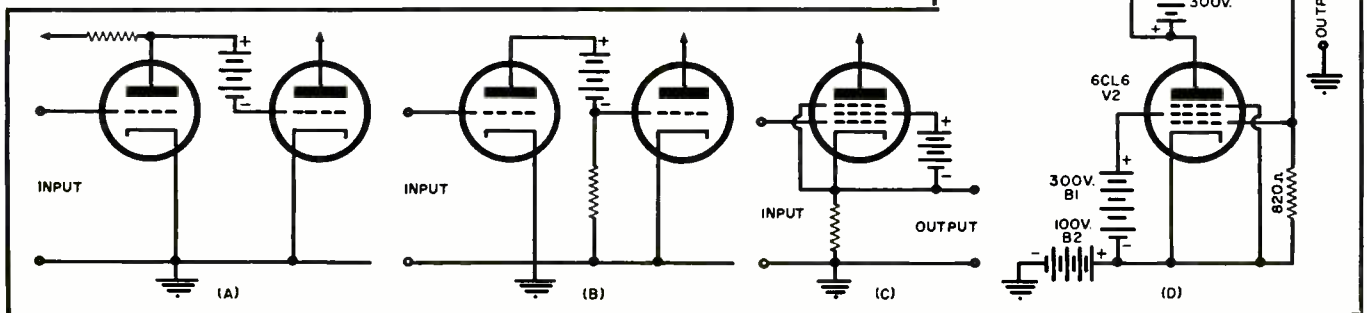

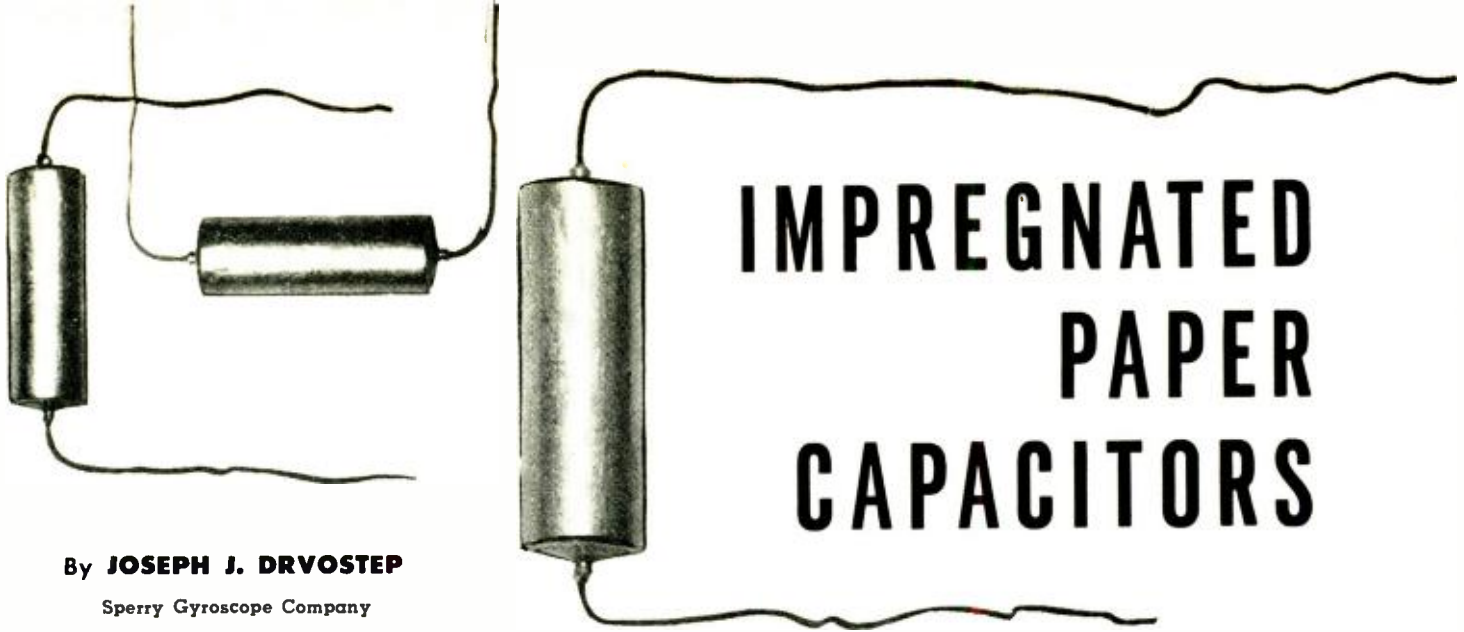

IMPREGNATED PAPER CAPACITORS

By **JOSEPH J. DRVOSTEP**
Sperry Gyroscope Company

TO MEET the wide range of requirements in electronic circuits, many different types of capacitors have been developed, and the circuit designer must select the most suitable type to obtain the best results. This article reviews the construction and characteristics of impregnated paper dielectric capacitors, which are used more than any other type, and briefly discusses their application.

In certain tabulations of component failures¹, capacitors rank as the third most troublesome components used in electronic equipment today, next to resistors and electron tubes. Furthermore, since 43% of all the recorded failures have been attributed to engineering shortcomings, it is hoped that a review of capacitor characteristics and limitations will help to minimize failures in future designs.

All capacitors have some residual inductance L associated with the leads and plates, and also a finite value of shunt resistance $I.R.$ which is referred to as "insulation resistance." Except in electrolytic capacitors, the series resistance R_s can usually be neglected. The equivalent circuit of any capacitor is shown in Fig. 1. Values of L , R_s and $I.R.$ vary over wide limits, depending on the mechanical design and type of insulation or impregnant used, and must be considered along with the capacitance value, voltage and current ratings, temperature coefficient, stability, etc., when a capacitor is being selected for a particular job.

Construction

The impregnated paper capacitor is normally made by winding a roll that consists of two metal foils separated by two or more sheets of paper, as shown in Fig. 2. The capacitor roll can be wound in a broad range of sizes using various

Construction, characteristics and application of impregnated paper dielectric capacitors.

thicknesses of paper (depending on the voltage rating required), and by means of series or parallel connections can furnish a large range of capacitance values and working voltages.

Following a drying period, to drive out moisture, the foil and paper rolls are impregnated with a wax, oil or a synthetic compound. Although some of the characteristics of paper are inferior to those of certain other dielectrics, the balance between desired characteristics, size, and cost favors impregnated paper more often than any other dielectric. Paper is relatively easy to assemble and impregnate, and has a high dielectric constant. A wide assortment of characteristics can be obtained by using different types of impregnants.

In the processes which convert wood to paper, contamination occurs in the form of metal, carbon and scale. Although most of these particles are removed, the small number remaining determines the dielectric strength of low voltage capacitors utilizing paper 0.2 to 0.4 mil thick. When two papers are used, the chance of two particles lining up to cause a short circuit is about 1 in 5,000,000. The chance of a single particle large enough to pierce both sheets is greater, and the chance of holes in the paper is comparable. For these reasons, a single layer of paper is not a practical dielectric, although it would permit a size reduction. Similarly, a capacitor section utilizing two layers of 0.2 to 0.3 mil paper is

Fig. 1. Equivalent circuit of any capacitor. R_s is usually ignored except in electrolytic capacitors.

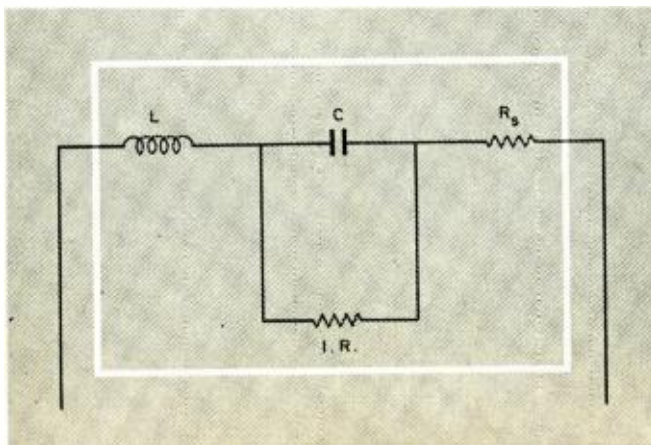

Fig. 2. Thickness and number of layers of insulating paper are governed by capacitor's voltage rating.

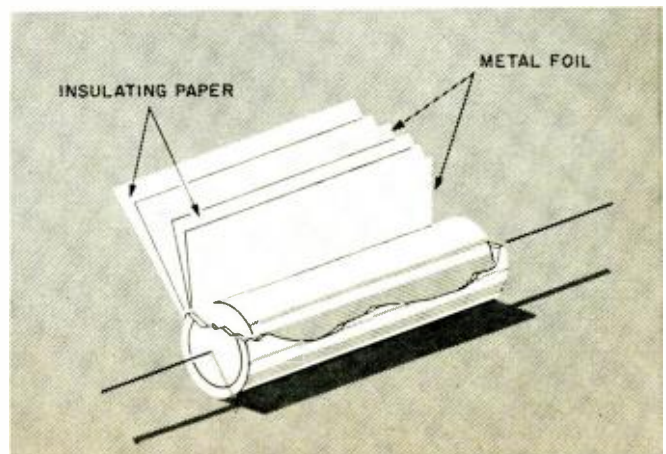

TABLE 1	
SEALS	
TYPE	CHARACTERISTICS
PLASTIC MOLDED CASING	DIFFICULT TO SEAL TERMINATIONS. NO PLASTIC IS IMPERVIOUS TO MOISTURE. LIMITED IN TEMPERATURE RANGE.
WAX COATING	MECHANICALLY WEAK. CRACKS AT LOW TEMPERATURES.
FUSED GLASS — METAL SEAL	HERMETIC SEAL. SUBJECT TO AGING. MINUTE CRACKS MAY DEVELOP. WARM MOISTURE CAN REDUCE INSULATION.
WELDED SILICONE RUBBER SEAL	NOT A TRUE HERMETIC SEAL. VIBRATION AND SHOCK RESISTANT. VIRTUALLY UNAFFECTED BY SOLDERING. SUBJECT TO AGING.

TABLE 2	
TERMINATIONS	
TYPE	CHARACTERISTICS
EXTENDED FOIL	LOW SERIES RESISTANCE. GOOD AT ALL VOLTAGES.
LAI-D-IN TAB	LARGER EFFECTIVE CAPACITANCE AREA. SERIES RESISTANCE HIGH. UNSATISFACTORY AT LOW VOLTAGE.
WELDED FLAG TAB	IMPROVEMENT ON LAI-D-IN TAB CONSTRUCTION. WITH CARE, CAN BE USED AT ONE VOLT OR LESS.

Table 1. Characteristics of four types of seals. Table 2 shows means used for electrical path between foil and outside circuits.

normally limited in size to about 1 μ fd., to minimize the probability of dielectric breakdown.

The impregnated paper dielectric must be free of air, water, and other impurities likely to engage in chemical action. Impurities increase the dielectric loss and leakage current, and under alternating voltage they produce heat which further increases the leakage and losses. However, the most serious effects are noted when a steady direct voltage is applied to the capacitor, and electrolysis takes place.

Effectiveness of sealing impregnated capacitors has developed through the years as the quality of the capacitors has improved and also as the conditions of use have become more severe. Types of sealing used today include: (1) molded plastic casing, (2) wax or bitumen coatings, (3) fused glass-metal seal, and (4) welded silicone rubber seal. Characteristics of these seals are noted briefly in Table 1.

Two basic methods are used to make electrical contact between the capacitor foil and the external connection. They are known as the "extended foil" and "laid-in tab" constructions, as illustrated in Table 2.

In the "extended foil" method, the two capacitor foils are

wound with one of the foil electrodes extended beyond the dielectric at one end of the roll, while the other foil extends beyond the dielectric at the other end. The protruding foil is then pressed and soldered together and the end terminal is soldered to the foil.

A "laid-in" or inserted tab method is used to decrease the volume of a section by eliminating the extensions of foil and extra insulation. The tab may consist of a metal band wound into the section for several turns, but is often merely the lead wire flattened at one end, providing a very small contact area. Electrical contact between tab and foil depends on the pressure between these parts, and is primarily affected by contact area and degree of compression. The welded flag tab consists of a metal strip welded to the tab to increase the area of contact with the foil about tenfold; exact minimum operating voltage varies somewhat with the design, voltage rating and operating temperature range.

In general, for small tubular capacitors or for capacitors to be used at very low voltages, the extended foil construction is most suitable. When laid-in tab capacitors are desired because of their high volume efficiency, several factors should be considered in their application:

1. Low voltages cannot break down the high resistance film which forms on the tab and foil, nor can they break down any impregnant that may seep in between the tab and foil.
2. In high alternating current applications, good contact must be maintained between terminals and capacitor foils. The user should clearly specify the a.c. current to be handled, so that a suitable tab design may be provided.
3. In high frequency applications, series resistance of tab units is relatively high and the Q decreases with increased frequency.
4. The discharge currents for energy storage or repetitive pulse applications can be very high, particularly when the capacitor is discharged through a low resistance circuit. A good tab design must be provided to avoid tab burn-out. It is essential that the user clearly state his circuit conditions to preclude failures.

Characteristics

Impregnated paper capacitors are available in capacitance values from 250 μ fd. to 10 μ fd. in individual sections. There is no practical upper limit for multiple sections. A capacitance tolerance of $\pm 10\%$ or broader can be obtained by design, whereas $\pm 5\%$ or less requires special processing or selection by the manufacturer. A practical means of obtaining close tolerances is to utilize preselected pairs to obtain the total capacity required.

The temperature coefficient of capacitance depends on the temperature coefficient of the impregnant and is independent of retrace effects. An impregnant is normally required because the paper voids must be filled to prevent ionization.

Stability of a capacitor depends on the impregnant, and the manner in which the paper and foil are rolled; the extent to which the foil and paper can move after the capacitor is made determines the capacitance retrace ability. Size and shape also affect stability; a long section of small diameter has better inherent stability than a short section of large diameter because there are fewer layers of paper and foil subjected to external stresses.

Molded tubular units are more stable than liquid impregnated metal-cased capacitors. Sections are rolled tightly, and the roll is compressed during molding with gases released through an eyelet, thereby "stress annealing" the section. The capacitance changes during the first temperature cycle, but subsequent temperature cycles have little effect. However, where operation in a high humidity atmosphere is required, molded tubulars are unsatisfactory because the absorption of moisture causes chemical deterioration of the capacitor section. Metal-cased units with a solid impregnant have stability comparable to molded tubulars.

TABLE 3	
TYPES OF FAILURE	
CAUSE	COMMENTS
CONDUCTING PARTICLES IN PAPER	OVER-VOLTAGE TESTS USUALLY ELIMINATE FAULTY UNITS
THERMAL INSTABILITY	HEAT OF ENERGY DISSIPATION IN DIELECTRIC MAY CAUSE BREAKDOWN
VOID IN DIELECTRIC	DISCHARGES THROUGH VOIDS IN DIELECTRIC MAY OCCUR, CONTINUED DISCHARGE CAUSES CARBONIZATION AND EXTENSION OF VOIDS
ELECTROCHEMICAL DETERIORATION	MOST COMMON CAUSE OF FAILURE IN D-C SERVICE. D-C VOLTAGES ENCOURAGE ELECTROLYSIS. DETERIORATION INCREASES WITH TEMPERATURE AND IS ACCELERATED BY CONTAMINANTS
CHEMICAL DETERIORATION	WITH NO VOLTAGE APPLIED, CAPACITOR MATERIALS SLOWLY DETERIORATE. HIGH TEMPERATURES (100-125°C) AND MOISTURE SPEED CHEMICAL ACTION

Table 3. Causes of and comments on types of capacitor failure.

The combination of the dielectric and impregnant determines the insulation resistance of a capacitor section and represents the net mobility of the ions in a capacitor. For each 10° C rise in operating temperature, the insulation resistance of a normal capacitor decreases 50%. Although capacitors can be made with insulation resistance up to one million megohms per section, the insulation resistance of metal-cased units is limited by the dielectric properties of the material used for the end seals.

If a well-insulated impregnated paper capacitor is instantaneously discharged, it will slowly collect a new charge at a lower voltage level. The capacitor acts as if a charge were absorbed by the dielectric and then released gradually. This phenomenon, known as dielectric absorption, is present in different amounts in all film dielectric capacitors. The extent to which a capacitor polarizes depends on its dielectric constant, temperature, relative resistivity of the dielectric, absorptive properties, and the period of time during which the charging voltage is applied.

Dielectrics containing large polar molecules, when subjected to an electric field, take an appreciable time to build up an electric charge because of the finite time required for the polar molecules to rotate in the field. When capacitors are made of such dielectrics, they do not build up to the full applied charging voltage instantaneously, nor do they discharge completely in a short time. Impregnants such as mineral oil and polyisobutylene are essentially nonpolar and show zero absorption or hysteresis effect. Paper is a dielectric that has relatively high dielectric absorption, whereas polystyrene is the only useful dielectric that shows zero dielectric absorption. Dielectric absorption causes the effective capacitance value to decrease as the frequency increases, a factor to be considered where changes in capacitance value must be limited regardless of the operating frequency. This property also has to be considered in timing circuits where a capacitor may be required to discharge completely in a fraction of a second.

The power factor of a capacitor (capacitor resistance divided by capacitor impedance) establishes the phase angle between voltage and current, and is determined by the capacitor losses in series with the capacitor. Dielectric losses (leakage, dielectric absorption, etc.) appear as resistance in parallel with the capacitance, whereas ohmic losses (electrodes, leads, etc.) are in series with the capacitance. The effect of series resistance transcends that of parallel resistance, especially at higher operating frequencies.

Dissipation factor (capacitor resistance divided by ca-

pacitor reactance) is normally used in lieu of the power factor for checking capacitors with a low series resistance. Except for electrolytic capacitors, the dissipation factor is so low that it is practically equal to the power factor.

The factor of merit Q is the reciprocal of the dissipation factor for values of Q greater than 10. Q measurements are normally used to determine the quality of capacitors at radio frequencies.

Design Factors

Three main factors² determine the design of a capacitor: (1) the useful life expected from it, (2) the ambient operating conditions, and (3) circuit conditions, such as voltage, frequency, discharge rate, etc. Assuming that the design effectively excludes the effects of moisture and reduced pressure on the dielectric, the life of a capacitor at a given voltage generally depends on the dielectric thickness and the operating temperature. The length of life of a fibrous dielectric such as paper can be altered by the impregnant selected.

The useful life of a capacitor is considered to end when any one characteristic has changed so that the circuit in which the capacitor is used stops functioning properly. End of life may be caused by dielectric breakdown or a change in capacitance or insulation resistance, and can be defined only by the user of the capacitor.

Experiments³ have shown that the minimum life of a paper capacitor varies approximately as $1/E^n$, where E is the d.c. voltage applied. The value of n was found to vary from 4 to 6 for impregnants used during World War II at ambient temperatures up to 85° C and stresses up to 1500 volts per mil of impregnated paper. Also, n has been observed to vary considerably with applied voltage, and to differ for various liquid-solid combinations.

The relationship between operating temperature and life has not been well established, but from 20° to 80° C, test data⁴ indicate that the life is halved for each 10° C rise in operating temperature. If the insulation resistance of a capacitor decreases more than 50% with each 10° C rise, the capacitor will probably have a short life. Failure of capacitors in service may be caused by the factors briefly noted⁵ in Table 3.

Voltage ratings normally given apply at 20-30° C, sea level, and 80% maximum relative humidity. In all instances where capacitors are in hermetically sealed cases, the only

(Continued on page 31)

Fig. 3. Panel-mounted capacitors showing two types of terminals.

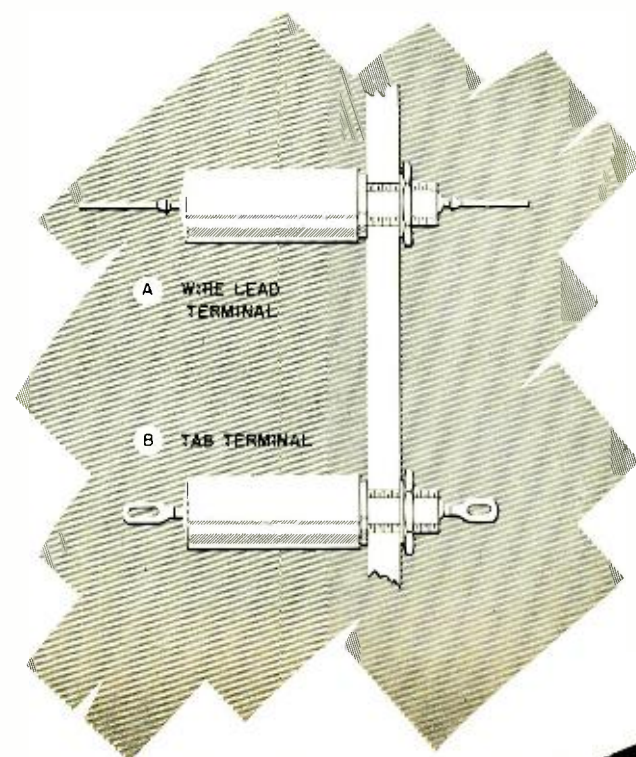

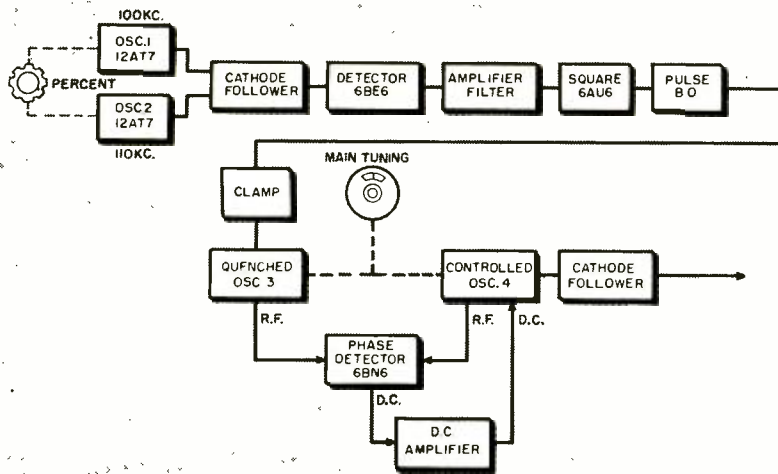
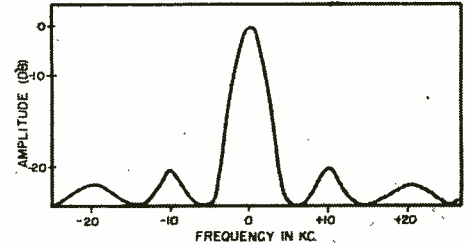

Fig. 1. Diagram of variable frequency signal source showing how output is obtained from an oscillator controlled by a quenched oscillator and phase detector.

Fig. 2. Sidebands produced from the quenched oscillator must be down 20 db or more from the fundamental frequency.



By WILLIAM A. HAYES

Servo Corporation of America

SYNTHESIZING CRYSTAL STABILITY

Stability equivalent to that of a crystal oscillator is obtained with a variable frequency signal source.

HIGH stability and flexibility in oscillators are always desirable. Numerous systems for synthesizing crystal stability have been devised, such as locking an oscillator to one of many harmonics of another oscillator or achieving stability by means of beating methods. The following paragraphs describe a new means of generating a variable signal which retains the stability features of a crystal oscillator. This signal can be used as a local oscillator frequency for a receiver, a v.f.o. for a transmitter, a high stability source for a signal generator, or as a means of attaining high stability of equipment at u.h.f. and microwave frequencies.

Operation

Referring to the block diagram of the signal source (Fig. 1), two crystals—one at 100 kc. and another at 110 kc.—are combined to obtain a 10-kc. beat. This frequency is then filtered and squared in a limiter stage so that a blocking oscillator can be triggered, producing a pulse which is used to quench an oscillator tunable from 2 to 4 mc. As the variable oscillator is tuned, it will lock to a harmonic of the 10-kc. frequency at 10-kc. increments, and will effectively be corrected ten thousand times a second.

It is important that the quenching pulse be as narrow as possible; when

an oscillator is quenched, sidebands are produced, and these sidebands (Fig. 2) should be down 20 db or more from the fundamental so that there are no ambiguities of frequency control in the system. There is a limit also as to how narrow the pulse may be—it can be no shorter than one cycle of the quenched oscillator when the oscillator is tuned to its lowest frequency; in this case, the lowest frequency is 2 mc. and one cycle at this frequency is $\frac{1}{2}$ μ sec. At higher frequencies, greater difficulty may be encountered in obtaining a pulse which is narrow enough.

The quenched oscillator (Osc. 3, Fig. 1) is fed into the control grid of a phase detector (6BN6) where considerable limiting takes place, removing any residual amplitude modulation on the quenched oscillator output. Another oscillator (Osc. 4, Fig. 1) that is on the same frequency as the quenched oscillator and tracks with it is also fed into the phase-sensitive detector, producing a d.c. voltage proportional to the phase difference of the two. This voltage is fed into a d.c. amplifier that in turn controls a small portion of the inductance of the tank circuit of the controlled oscillator (Osc. 4, Fig. 1). A small variable inductance is used in series with a main tank coil and is the means of controlling the frequency; known as an "Increductor," this device was recently

developed by C.G.S. Laboratories, Inc.

Vernier control of the frequency between the 10-kc. increments is accomplished as follows. It will be noted in Fig. 1 that the two low-frequency oscillators (Osc. 1 and 2) are linked mechanically with a percent control. This control operates two variable capacitors, one in series with each crystal, so that the beat frequency can be changed 25 cycles. A small change of the 10-kc. beat will make a large change when multiplied up to 2 mc., and a 25-cycle change represents 10 kc. or more when the quenched oscillator frequency is higher. The change at higher frequencies is greater, necessitating the percentage calibration of the vernier dial. By using this method, it is possible to achieve complete frequency coverage.

Circuitry

The two low-frequency oscillators are identical and are of the two-terminal variety (Fig. 3A). As a high Q is desirable for producing sine-wave oscillations, the plate of each oscillator section is resonated with L_1 and C_1 . The second half of each oscillator tube is used as a cathode follower.

It will be noted that resistors R_1 and R_2 are inserted between the low end of the cathode resistor and ground. This arrangement places a larger voltage across the crystals and permits the tubes to be operated at optimum values, producing harmonic-free oscillations. At this point, it might be mentioned that some crystals—especially the cheaper cuts—may have a tendency to oscillate on multiple modes, producing a small amount of FM in the output. A small trimmer capacitor C_2 provides a means

(Continued on page 30)

TECHNICAL BOOKS

"MATHEMATICS OF ENGINEERING SYSTEMS" by Derek F. Lawden, Senior Lecturer in Mathematics, College of Technology, Birmingham. Published by *John Wiley & Sons, Inc.*, 440 Fourth Ave., New York 16, N. Y. 380 pages. \$5.75.

Mathematical methods which may be used to analyze the behavior of a diversity of physical systems have been gathered together in this book with their applications to form a modern course of applied mathematics, suitable for students of electronics, electrical engineering, applied physics and instrument technology. Including an elementary introduction to recent work in the field of linear and nonlinear differential equations, it should also prove useful to practicing engineers and laboratory physicists.

Emphasis has been placed upon the mathematical methods rather than on engineering problems, although each method is used to solve a number of practical problems. All of the exercises have been prepared to enable the student to become proficient in the use of the methods described in the text, and to assist him in applying these methods to practical problems and arriving at conclusions of real significance.

"CIRCUITS AND NETWORKS" by Glenn Koehler, Professor of Electrical Engineering, University of Wisconsin. Published by *The MacMillan Company*, 60 Fifth Ave., New York 11, N. Y. 349 pages. \$6.50.

The material in this book is the outgrowth of several years of teaching a course in circuits and networks. Much of the material is borrowed from that which was once found almost exclusively in the electronics and communications fields but which has now become basic to practically all phases of electrical engineering.

In this volume, the author has attempted to show that some of the basic fundamentals of circuits and networks are equally applicable to both the communications and power fields. Notable examples of this are the chapters on transmission-line parameters, on general transmission-line theory, and on transformers and reactors.

Other chapters cover methods for analyzing and solving circuits and networks, network theorems, properties of simple frequency-selective circuits, coupled circuits, four-terminal network analyses and impedance matching, filters, attenuators and equalizers.

What are YOUR paper tube requirements?



- Special size or shape
- Critical tolerances
- High dielectric strength
- High tensile strength
- Dimensional stability
- Low unit cost
- Prompt delivery in any quantity

PRECISION *can*

meet your exact specifications

You can order from Precision in an infinite variety of sizes, shapes, I.D.'s or O.D.'s and be sure of the finest quality and construction, plus uniformity throughout. You can specify kraft, fish paper, acetate, combinations, phenol impregnation, etc., whichever material is best suited to your particular application.

Precision's modern high production facilities and rigid manufacturing control bring you all these advantages at lowest possible cost!

Request samples and Arbor List of over 2000 sizes.

PRECISION BOBBINS CUT COIL COSTS

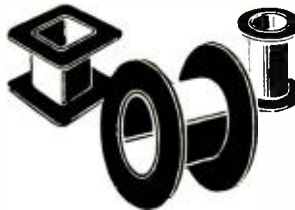

Eliminate rejects, waste, loss of time. Order in any size or shape, plain or fitted with leads, slots or holes. Flanges cut to your specification. Ask for samples and bulletin.

Sales Representatives in:

New England:
Framingham, Massachusetts, Framingham 7091

Metropolitan New York, New Jersey:
Jersey City, New Jersey, Journal Square 4-3574

Upstate New York:
Syracuse, New York, Syracuse 4-2141

Northern Ohio, Western Pennsylvania:
Cleveland, Ohio, Atlantic 1-1060

Indiana, Southern Ohio:
Logansport, Indiana, Logansport 2555

Missouri, Southern Illinois, Iowa:
St. Louis, Missouri, Sterling 2318

Maryland:
Baltimore, Maryland, Plaza 2-3211

Philadelphia, Camden:
Philadelphia, Pa., Chestnut Hill 8-0282

California:
Pasadena, California, Sycamore 8-3919

Canada:
Montreal, Quebec, Canada, Walnut 0337



PRECISION PAPER TUBE CO.

2063 W. CHARLESTON ST.

CHICAGO 47, ILL.

Plant No. 2: 79 Chapel St., Hartford, Conn.

NEW PRODUCTS

I.F. RADAR AMPLIFIERS

Miniature lightweight i.f. radar amplifiers incorporating low-noise front ends are now in production at *RS Elec-*

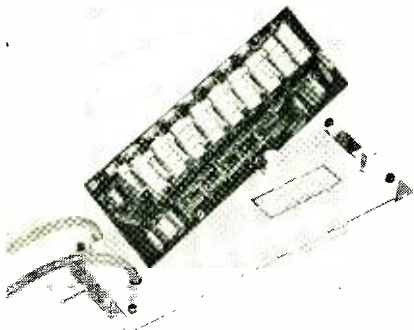

tronics Corporation, 435 Portage Ave., Palo Alto, Calif. Standard circuits are available to provide for low impedance output, video detection, fast time constant, tuning detection, video amplification, video limiting, etc.

General specifications typical of these amplifiers include: center frequency, 20-100 mc.; bandwidth, 2-12 mc.; gain, up to 120 db; automatic and/or manual gain control, 100 db or greater; noise figure, better than 2 db; and ambient temperature operating range, -65°C to $+100^{\circ}\text{C}$. The units will operate under 30 *g* shock and 10 *g* vibration for extended periods.

D.C. POWER SUPPLY

Model 323 is an unusually compact 200-325 volt, 300 ma., regulated d.c. power supply manufactured by *Power Designs Inc.*, 119-22 Atlantic Ave., Rich-

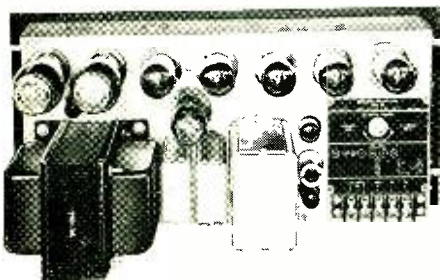

mond Hill, 19, N. Y. Stability is better than 0.1% for line or load variations, ripple less than 1.0 mv., and transient response less than 150 μsec .

With a panel height of $8\frac{3}{4}$ " and a depth behind the panel of $9\frac{3}{4}$ ", the Model

323 is designed for reliability under continuous service conditions. It features "reliable" type series tubes, oil-filled capacitors, boro-carbon resistors, Helipot voltage control, 40° rise transformers and *Weston* meters.

TRANSIENT RECORDER

Up to four signals can be simultaneously recorded by the Type 104 magnetic transient recorder developed by *Magne-Pulse Corporation*, 140 Nassau St., New York 38, N. Y. Providing a frequency response of d.c. to 2 kc., a 1-second record period, and simultaneous playback of any two channels, this equipment also features the use of magnetic discs which



can readily be removed and stored, or erased and used again.

Applications for the Type 104 include the recording of transients in aircraft, power lines, petroleum exploration, medical research, electronic analysis and other related fields. Use of the magnetic discs greatly simplifies the analysis of transients recorded, since such recordings can be fed to an oscilloscope without need for searching, splicing, and introducing tape discontinuities.

POWER LINE CARRIER

The first transistorized power line carrier to be placed in commercial production was recently announced by *Motorola Communications and Electronics Inc.* This new narrow-band frequency-shift apparatus utilizes transistors to achieve maximum reliability and continuity of service with a minimum of maintenance. Transmission of high speed information is provided at the same close channel spacing of 500 cycles throughout the 40-200 kc. band.

While the heterodyne transmitter

(top) uses transistors for all but the power output stage, the superheterodyne receiver (bottom) is completely transistorized. The transistors make possible a

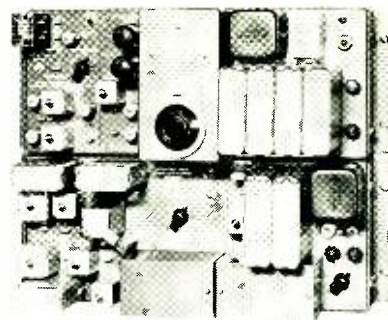

reduction of power consumption of up to 75%, only 6 watts being consumed by the receiver which operates without any perceptible generation of heat. For more information, write to *Motorola Communications and Electronics Inc.*, Technical Information Center, 4501 W. Augusta Blvd., Chicago 51, Ill.

RIDGE GUIDE BULKHEAD ASSEMBLY

A ridge wave guide bulkhead assembly has been developed by *Airtron, Inc.*, for use with C-band or X-band commercial airborne weather penetration radar. Having electrical characteristics equivalent to those of similar straight sections, it permits passage of a run of ridge wave guide through aircraft bulkheads, particularly through pressurized bulkheads where no leakage of air is permissible.

This assembly consists of a section of ridge wave guide with a circular plate brazed radially to its center. A retaining plate of equal diameter is used to

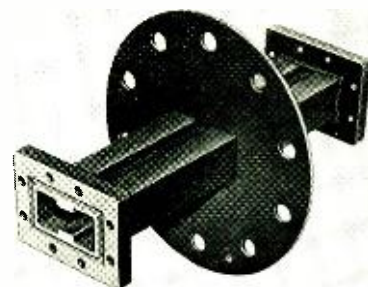

bolt the wave guide plate fast to the bulkhead, while an intermediate rubber gasket provides an airtight seal. Additional information is contained in Catalog 2040, available from *Airtron, Inc.*, Dept. A, 1103 W. Elizabeth Ave., Linden, N. J.

DECADE PULSE FORMING NETWORK

For front panel mounting, the new decade pulse forming network announced by the *ESC Corporation*, 534

Bergen Blvd., Palisades Park, N. J., requires only 2½" x 1½" of front panel space. Designated as the Model #21-19, it supplies pulse formations from .25 to 2.0 μsec. in width by means of three miniature toggle switches. The circuit is arranged to provide a residual pulse width of .25 μsec. at all times.

Other features of this compact delay network include an impedance of 200 ohms ±10% with a 35% maximum attenuation for 2.0-μsec. delay of the reflected pulse. Each unit is potted in epoxy resin and enclosed in a hermetically sealed case.

AUTOMATIC TUNING CONTROL

Automatic tuning of frequency-shift code receivers can now be provided by a tuning control unit announced by C.G.S Laboratories. Known as the Model TL-1 TRAK tuning lock, this unit keeps a receiver tuned accurately to an incoming frequency-shift signal at all times, even though the incoming signal may drift in frequency or the receiver tuning change.

Model TL-1 includes a control chassis and a separate electrically controlled capacitor which is connected to the tuning circuit of a receiver. It is applicable to either variable-tuned or crystal-controlled receivers. For further infor-

mation on this unit, write to Melvin L. Jackson, C.G.S. Laboratories, 391 Ludlow St., Stamford, Conn.

CRYSTAL MULTIPLIER

Designed to produce frequencies above the range of currently available tubes, the De Mornay-Bonardi DB-350 crystal multiplier enables experimentation in the "ultramicrowave" region up to



90,000 mc. It is intended especially for harmonic power generation at the second, third, fourth, or fifth harmonic.

The DB-350 consists of an input wave guide of a size appropriate to the input frequency, an output wave guide, and a tunable crystal holder. A BNC connector permits the introduction of low frequency modulation, or biasing of the crystal.

Additional information may be obtained from L. C. Spoor, De Mornay-Bonardi, 780 S. Arroyo Parkway, Pasadena, Calif.

Microwave Testing

(Continued from page 15)

Figure 7 also shows the effect of placing a Fiberglas weatherproof cover over the open mouth of the horn, which normally would produce a troublesome reflection. In this antenna, it is a continuation of one of the side walls of the horn. Consequently, outgoing signals strike it at an oblique angle. The reflections that come from it are not returned directly and are not focused by the reflector back at the wave guide. Therefore, the over-all reflected energy was found to be rather low. As measured with this equipment, however, a reflection appeared to originate at a point 16' in front of the mouth of the horn. Such a reflection is accounted for by the fact that energy reflected from the cover, because of its oblique position, bounces back and forth inside the horn before getting back into the wave guide.

This short-pulse equipment is being used for many other purposes in wave guide research. The above examples, however, indicate its possibilities in design and development testing.

Broadband RF Power Meters

THE CHOICE OF ALL ARMED SERVICES
FOR MICROWAVE POWER MEASUREMENTS

POWER: PULSE and CW — 5μW to 5W average
FREQUENCY: 20MC — 10,000MC
ACCURACY: 5% Absolute at all ranges,
frequencies, temperatures

- **INDICATIONS:** Direct Reading
- **CALIBRATION:** Compensates for All Variables
- **R-F COMPONENTS:** 3, 6, 10 and 20db Attenuators, Bolometer Mount and Elements, R-F Cable
- **BOLOMETER:** Broadband, High Overload Capacity
- **PLUMBING:** 3/8" and 7/8" 50-ohm Coaxial
- **POWER SOURCE:** 115VAC ±15%, 50-1000 cps
- **CONSTRUCTION:** Rugged, meets all JAN, MIL requirements

TYPICAL APPLICATIONS

Microwave Links . . . Television . . . Communications . . .
Radar . . . Telemetry . . . Signal Generators . . .
Laboratory Standards.

Write for descriptive literature to Department RE-5M

Bruno - New York Industries Corporation

DESIGNERS AND MANUFACTURERS OF ELECTRONIC EQUIPMENT
460 WEST 34th STREET • NEW YORK 1, N. Y.



NEWS BRIEFS

AIRBORNE RADAR SET

Du Mont's Type APS 42 B airborne radar set is undergoing exhaustive tests at Braniff International Airways, where it has been installed aboard one of the DC-6 commercial airliners. Developed by Allen B. Du Mont Laboratories, Inc.,



760 Bloomfield Ave., Clifton, N. J., the Type APS 42 B is designed specifically to warn pilots of dangerous terrain and hazardous weather, and to aid in navigation. It has already been successfully used in military transport planes, and the Navy's new Lockheed Constellations

are now being equipped with the set. Information from distances up to 200 miles can be received by this compact and highly sensitive set. The Type APS 42 B consists of only six basic units: an antenna, a receiver-transmitter, control unit, synchronizing unit, and two azimuth-and-range indicators. Shown here in the pilot's compartment is one of the azimuth-and-range indicators.

MAGNETIC RESEARCH PROGRAM

The U. S. Signal Corps has joined the Atomic Energy Commission and the Office of Naval Research in supporting Carnegie Institute of Technology's search into the nature of magnetism. Professor Jacob E. Goldman, head of the institute's magnetic research laboratory, recently received \$26,500 from the Signal Corps to further the study of fundamental magnetic properties of metals, alloys and salts.

Work under the various government projects is part of Carnegie Tech's long-range magnetic research program.

There is great interest in this field at the present time due, in part, to the wide use of magnetic materials in instrumentation and computing devices.

"AUTOMATED" PUNCHING MACHINE

Considerable time-and-cost savings over conventional drill and punch-die methods can be effected with an "automated" production machine developed by the Engineering Products Division of Radio Corporation of America, Camden, N. J. Said to be the first of its kind ever built, it "triggers" punches of virtually any pattern of holes for components in electronic printed-circuit panels.

Called a printed-circuit board programmed punching machine, the unit is operated by a glass-based cloth tape into which "master" holes are punched. Any number of control tapes can be used, each with one or more patterns. The machine will perforate, in only 45 seconds, any combination of holes in any number of circuit patterns contained on a board up to 6" x 17.6" at a rate of 12,000 holes per minute.

COLOR TV-MICROSCOPY SYSTEM

A new technique of magnifying microscopic details of pathological tissue was demonstrated by the General Electric Company at the American Medical Association National Conference on Post-graduate Medical Television Education held at Chicago in February. The magnifying system, which features the use of closed-circuit color television, can magnify a microscopic specimen, live or dead, up to 15,000 times.

Specimens of pathological tissue, mounted on slides, were placed in view of a specially adapted TV camera-microscope. The full color image, picked

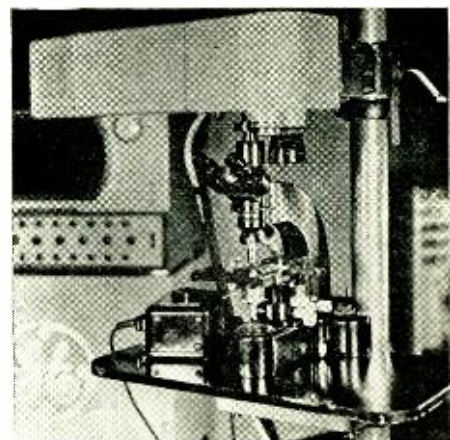

up by this microscope, was transmitted via coaxial cable to a television projector, and further magnified as it was projected onto a 4' x 6' screen. The demonstration was given in conjunction with a talk by Ralph S. Yeandle, of General Electric Company, who discussed some

TV-AM-FM SET PRODUCTION

Information based on latest reports from RETMA.

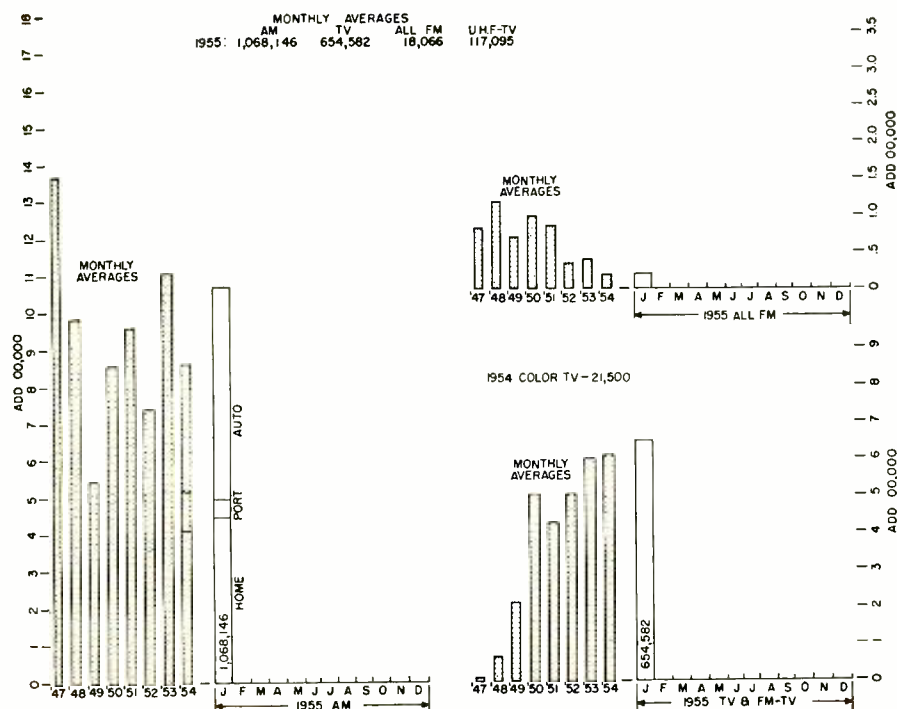

of the more important applications of this system in the field of medicine.

AIRCRAFT FIELD TEST STATION

At Norwood Airport, just outside Boston, a field test station has been opened by *Laboratory for Electronics,*

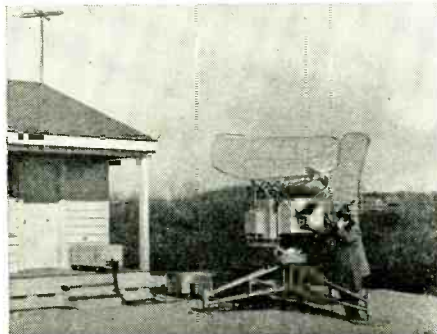

Inc., 75 Pitts St., Boston, Mass., manufacturer of the SPAR ground control approach landing system. Part of the test laboratory building is shown in the photograph, with Jackson Cook, project engineer, at the SPAR antenna test point. The test station provides final check-out, under actual flight conditions, on each SPAR and other units produced by this firm.

CANNON EXPANDS

As part of its 1954-55 expansion program, *Cannon Electric Company*, electronic components manufacturer, has completed plans for a new administration and engineering building. One story high and covering 30,000 sq. ft., the new building will be erected across from the main Humboldt Street plant in Los Angeles, Calif., thus providing for the expansion of present crowded production facilities.

MAGNETIC SHIELDING MATERIAL

Magnetic shielding material has been developed by *Perfection Mica Company*, 20 N. Wacker Drive, Chicago 6, Ill., that is said to be superior to any other material now available. Consisting of a special alloy core on which specially compounded coatings are applied in certain sequences, it can be drilled, tapped, sawed and dropped without impairing its shielding efficiency. It apparently cannot be saturated and has a retentivity so small as to be unmeasurable.

Results obtained in a series of comparative tests conducted to determine effectiveness with magnetostatic fields and electromagnetic fields of low and high flux density indicate that the *Perfection* coated shield, as it is called, is superior to the best soft iron alloy, alloy steel, or nickel alloy. Electrostatic shielding properties were also found to be good.

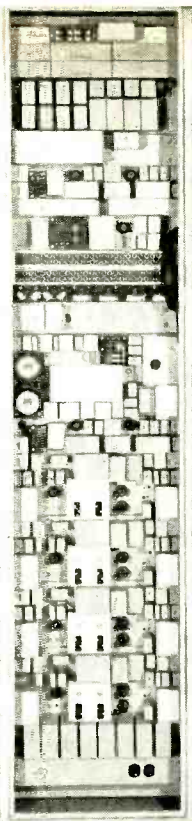

FOUR-CHANNEL OPEN-WIRE CARRIER-TELEPHONE SYSTEM.

This is a high-grade long-haul system compatible with three-channel type C, OA-11/FC and OA-12/FC systems. The fourth toll-grade channel has been obtained by advanced filter and oscillator-network design without changing the frequency allocation or degrading the performance of the three carrier channels or of the physical circuit. Transmission in one direction is in the band 3.4 kc to 15.65 kc, and in the other direction in the band 17.95 kc to 31.4 kc. On copper conductors repeater sections average 200 miles, and high-grade circuits several thousand miles in length can be maintained under all climatic conditions.

Type AN/FCC-10 Carrier-Telephone Terminal manufactured for the U.S. Army Signal Corps. This terminal includes regulated-tube rectifiers, d-c telegraph composite sets, line protectors, operator's telephone set, 4-wire terminating sets, v-f signal converter type CV-399/FCC, and all accessories to form a complete packaged 4-channel terminal. It is moisture- and fungus-proofed, and meets all applicable MIL specifications. It is a-c operated.

RADIO ENGINEERING PRODUCTS

1080 UNIVERSITY STREET, MONTREAL 3, CANADA

Telephone: UNIVERSITY 6-6887

Cable Address: Radenpro, Montreal

MANUFACTURERS OF CARRIER-TELEGRAPH, CARRIER-TELEPHONE AND BROAD-BAND RADIO SYSTEMS



YOUR CALLING CARD FOR A BRILLIANT FUTURE...

Bendix Missile Section is a major contractor in the U. S. Navy's guided missile program - a part of the "new look" in our defense plan. Our expanding program has many opportunities for senior engineering personnel: Electronics Engineers, Microwaves, Dynamicists, Servo-Analysts, Stress Analysts, Project Coordinators, and Designers. Take time now to look into the opportunities which Bendix can offer you. Write Employment Dept. M, 401 Bendix Drive, South Bend, Indiana.

Receiver Design

(Continued from page 9)

justment, the coupling can be set to provide either wide-band or narrow-band operation in the factory or in the field. Coupling is determined by the mounting holes in the transformer housing identified by "N" for narrow-band or "W" for wide-band.

The new low-i.f. of 290 kc. was chosen over the formerly used 455-kc. frequency because, for a given number of tuned circuits, it provides greater skirt selectivity and wider passband for weak signals in split-channel operation, which the FCC is now proposing for both the 25-50 mc. and 152-174 mc. bands (docket number 11253). This means that a receiver with the 290-kc. i.f. amplifier will provide not only better signal-to-noise ratio on very weak signals but greater rejection of strong adjacent-channel signals as well.

Figure 6 shows graphically the higher selectivity of a 290-kc. amplifier as compared to a 455-kc. amplifier of equal quality using the same number (12) of tuned circuits. Note the 30-db improvement in skirt selectivity where the curves cross the edge of an adjacent (20-kc.) channel as well as the broader passband at the "nose" of the curve.

Figure 5 is a disassembled view of a 6-coil i.f. transformer. Note that each

pair of coils is individually shielded from the others within the enclosing structure. There are only three connections to and from the complete transformer: B+, plate, and grid. Plate and grid connections are made by low-capacity, high-dielectric insulated wire, and internal channeling eliminates stray coupling that would otherwise tend to bypass the high selectivity of the tuned circuits and reduce the isolation provided by the transformer. This isolation accounts for steep side-wall attenuation which continues beyond the 140-db level.

The lifetime stability of the 6-coil transformer design is due in large part to the treatment of the individual windings in the manufacturing process. Other important factors are precise temperature compensation and excellent mechanical stability. Any coil will change its inductance when subjected to wide changes in temperature, but the change can be compensated for by the use of temperature-compensating capacitors having the proper temperature coefficient, provided only that the inductance retraces its temperature-vs.-inductance curve exactly. Windings in these 6-coil transformers will retrace accurately due to the construction and the treatment described below.

Coils are wound of insulated litz wire on universal winding machines and tested for inductance and Q. Each

is then baked in a 100° C oven for two hours to drive out any moisture that might be present, after which it is placed in a centrifugal varnish impregnator where varnish is forced into every tiny space around the wire of the coil. These coils are next baked for two hours at 60° C, after which they are given a varnish dip to enclose the outside completely and baked again at 60° C for two more hours.

Final treatment of the coils is a wax bath which further seals each winding. The coils are wound on molded durez forms which have rigidity, permanence, and electrical properties equal to ceramic materials. As a result of the varnish-wax treatment, the

transformers are stable enough to permit the manufacturer to guarantee the selectivity of each receiver for life.

Inasmuch as it is never necessary to retune the transformers, the tuning adjustments are covered by an enclosing shield. However, retuning may be a beneficial prerogative in the case of channel-splitting, where a user desires to secure a clear channel by shifting his operating frequency one channel up or down. By moving the low-i.f. amplifier frequency the same number of kilocycles as the channel separation, the entire receiver can be retuned to the new channel frequency without the need to replace either the first or second crystal. The tuning range of the low i.f. transformers is sufficient to permit this procedure.

Audio Volume Control

Many methods have been devised and used to control audio volume of mobile receivers, but all have one or more shortcomings. The situation is complicated by the fact that there is usually a 17' to 20' length of multiconductor cable between the receiver and the control head where the volume control must be available to the user.

In the present system, volume control has been satisfactorily achieved by replacing the last resistor in the receiver de-emphasis network with a variable resistor (not a potentiometer), thus utilizing a two-lead connection between receiver and control head which makes it possible to balance out any hum or noise pickup due to other leads in the same control cable. In addition, the two leads are shielded throughout the length of the cable. This system permits full power output under the control of the operator; there is no interaction between squelch and volume controls, and no plate voltage is present at the control.

Metering System

Metering of both transmitters and receivers may be accomplished with any standard 20,000-ohm/volt meter having a 3-volt scale. Simple multipliers are employed so that the technician can always determine readily the actual currents or voltages in the circuits under test. Pin jacks are provided to check: (1) oscillator grid voltage (also multiplier grid voltage in high-band receiver), (2) second low i.f. grid voltage, (3) first limiter grid voltage, (4) second limiter grid voltage, (5) discriminator voltage, (6) plate supply voltage, and (7) primary source voltage.

The system permits metering two or more circuits simultaneously. It is advantageous, for example, to keep a continuous watch on center frequency by observing the reading on a meter in the discriminator circuit while checking receiver gain in one of the limiter jacks. Such a system facilitates accurate receiver adjustments.

The Sign of precision engineered

for greater **DEPENDABILITY**
QUALITY
CONSTRUCTION



AUDIO-POWER
PULSE

TRANSFORMERS AND INDUCTORS
High Temperature—Miniaturized

WRITE FOR
Our Latest
Brochure

INDUSTRIAL  **TRANSFORMER**
Corporation
GOULDSBORO PENNSYLVANIA

Personals



W. P. BOLLINGER, specialist in design and development of radar equipment for guided missiles, has been appointed assistant director of engineering of the guided missile section of *Bendix Aviation Corporation*, Mishawaka, Ind. Mr. Bollinger first joined the missile section, which is part of the *Bendix Products Division*, in 1953 as manager of weapons system development. He holds eight patents in the field of radar, and has 12 more applications pending.



EDWARD S. COBB has joined the Public Relations Department of *American Machine & Foundry Company*, New York, N. Y., as technical information manager. During the latter part of World War II, Mr. Cobb conducted tests at *Wright Aeronautical Corporation* on all types of aircraft engine ignition systems and coordinated results with various component manufacturers. Since 1947, he has been serving as a staff engineer on *McGraw-Hill's* Product Engineering magazine.



DR. RUDOLF G. E. HUTTER, formerly manager of the physical electronics branch of the Physics Laboratory of *Sylvania Electric Products Inc.*, New York, N. Y., has now been promoted to manager of the Physics Laboratory. As a research physicist, he has made numerous contributions to the field of electron optics, especially as it applies to design of cathode-ray and traveling-wave tubes. Dr. Hutter is an adjunct professor at Polytechnic Institute of Brooklyn.



A. E. KELEHER, Jr., who joined *Raytheon Manufacturing Company*, Waltham, Mass., as a sales engineer in 1948, has been named product manager of communications equipment. In 1949, he became product planning manager of mobile radio equipment, and subsequently handled various sales staff assignments; he will continue as a staff assistant on the product planning committee. Mr. Keleher holds a B.S. degree in physics and an M.S. in electronics.



DR. DAVID B. LANGMUIR has been appointed to the staff of the Guided Missile Research Division of *The Ramo-Wooldrige Corporation*, Los Angeles, Calif. For more than 12 years, Dr. Langmuir was engaged in government work with the Atomic Energy Commission, the Defense Department and the Guided Missile Committee. Prior to his government service, he was a research physicist with the *Rand Corporation* and a Teaching Fellow at M.I.T.



DR. A. MELVIN SKELLETT, holder of more than 70 major patents in electronics, has been named director of color TV tube planning and development for *Tung-Sol Electric Inc.*, Newark, N. J. Active in the electronics industry in research and administrative capacities for the past 25 years, Dr. Skellett has also served as consultant to the Research and Development Board of the Department of Defense. He is the author of over 30 published technical articles.

770

HICKOK

WIDE RANGE
HIGH SENSITIVITY

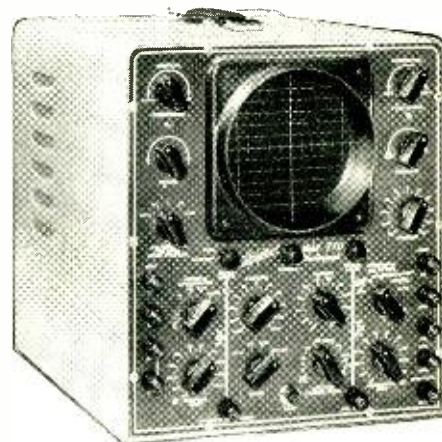

MODEL 770

Engineers' Scope

FREQUENCY RANGE:

- a. Vertical Amplifier:
 1. DC to 2.5 MC, 3db Down, with Band Width Switch in Narrow position.
 2. DC to 5 MC, 3 db Down, with Band Width Switch in Wide position.
- b. Horizontal Amplifier: DC to 500 KC, 3 db down.
- c. Sweep Circuit Oscillator: 2 cycles to 30 KC.
- d. Fixed Sweep Frequencies: 30 cycles and 7875 cycles.

INPUT IMPEDANCE:

- a. Vertical Amplifier: 2.2 Megohms—50 MMF.
- b. Horizontal Amplifier: 2.2 Megohms—50 MMF.

DEFLECTION SENSITIVITY:

- a. Vertical Amplifier:
 1. .010 RMS Volts Inch with Band Width Switch in Narrow position.
 2. .035 RMS Volts/Inch with Band Width Switch in Wide position.
- b. Horizontal Amplifier: .075 RMS Volts/Inch.

SPECIAL FEATURES:

- a. Illuminated, Calibrated Screen backed with a green filter for reducing incidental illumination in the room—for accurate measurements and comparisons.
- b. Built-In Calibrated Voltages: Peak-To-Peak—100, 10, 1, .1 Volts. Ideal for Observation of Color Burst at 3.58 MC.

THE HICKOK ELECTRICAL INSTRUMENT CO.
10534 Dupont Avenue • Cleveland 8, Ohio

COMMUNICATION REVIEW

MOTOR CARRIER FREQUENCIES

Now that the Federal Communications Commission has established 20 radio frequencies for use by trucking firms, the nation's motor carriers are permitted intracity radio operation on exclusive frequencies for the first time. According to communication officials of the *Radio Corporation of America*, Camden, N. J., supplier of two-way radio for motor fleets of utilities, service organizations and taxi companies, this should result in greater economy and efficiency in truck-freighting operations.

Under the new regulations, a radio-operated trucking firm has continuous control of rolling stock, can take advantage of sudden en-route orders within the city and on the road, and can exercise cost-saving dispatch of nearest trucks to a given pickup. The FCC action establishes 12 low-band 40-mc. frequencies and eight high-band 450-mc. frequencies for use by motor carriers.

MICROWAVE FOR CITY OF AUSTIN

Protective radio relaying and supervisory control will soon be provided for the City of Austin, Texas, by a complete microwave system (Type FR-FJ) to be furnished by the *Westinghouse Electric Corporation*, 401 Liberty Ave., Pitts-

burgh 30, Pa. The 2000-mc. system, to be installed this year, will provide 20 channels among 10 stations.

Due to a unique system-engineering technique, the system will provide a high degree of reliability in the microwave radio links without using standby radio equipment. This is accomplished by arranging the stations in a circular pattern; one of the stations normally acts as two terminals so that the system from this point looks like a complete loop. If a break in continuity should occur at any point in the circle, the stations on either side of the break automatically switch to terminal operation, and the original terminal stations switch to repeater operation.

TWO-WAY RADIO TO THE RESCUE

The mobile two-way radio system of the *National Supply Company* recently was instrumental in bringing aid to 25 children whose school bus had broken down in a section of Wyoming subject to sudden blizzards. H. E. Saylor, a *National Supply* field representative, was driving along a lonely section of U.S. 220 in a car equipped with two-way radio when he noticed the stalled bus. Upon investigation, Mr. Saylor called someone at the company store in Caspar, Wyo., who relayed the distress message

to school authorities. Another bus was quickly dispatched to the scene.

12-VOLT CONVERSION KITS

Twelve-volt conversion kits are now available from *Link Radio Corp.*, 125 West 17th St., New York 11, N. Y., for all *Link* two-way mobile radio equipment that was manufactured in previous years exclusively for 6-volt operation. All current *Link* models are being produced as 6/12-volt equipment with no component or wiring changes necessary.

THE ENGINEER IN COMMUNICATIONS

At the 75th Anniversary Meeting of the American Society of Mechanical Engineers held in New York City in February, Dr. E. W. Engstrom, executive vice-president, research and engineering, *Radio Corporation of America*, spoke on "What the Engineer Has Meant to Communications."

In his address, Dr. Engstrom stated that modern communication systems have been created largely through the ability of the engineer to translate new scientific knowledge into a flow of products and services for public use. Covering the growth of communication facilities since the time of the founding of the ASME, he emphasized the specific contributions of the engineer to that growth.

HIGH CYCLE POWER TRANSFORMER

Communication Accessories Company has announced a high cycle power transformer for airborne equipment—a plug-in type unit in a hermetically sealed case. With a volume of less than 1.65 cu. in., the newly designed *CAC* unit has a range from 400 to 6000 cps and efficiency up to 95%. Wattage is 6 mw. to 200 watts, and operating temperatures -55°C to $+155^{\circ}\text{C}$. For additional information, write to *Communication Accessories Company*, Hickman Mills, Mo.

RADIO TRANSMITTER-RECEIVERS

An eight-page comprehensive illustrated catalog has just been published by *G & M Equipment Co., Inc.*, 7315 Varna Ave., N. Hollywood, Calif., describing its line of Model 1006 100-watt-output radio transmitter-receivers. Features and general specifications are included.

PHOTO CREDITS

PAGE	CREDIT
7, 9.....	General Electric Co.
10, 11.....	Du Mont Television Network
12.....	ACF Electronics
13, 14, 15....	Bell Telephone Labs.
16.....	Nat. Bureau of Standards
17.....	Sperry Gyroscope Co.

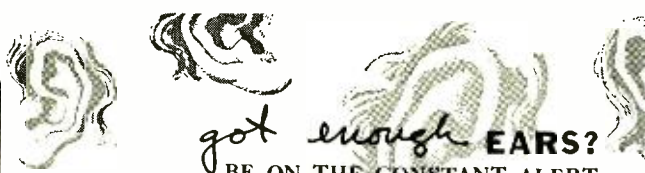

got enough EARS?
BE ON THE CONSTANT ALERT

All Departments Can Now Listen to Every Vital Message

MONITORADIO for a thoroughly coordinated 2-way communication system.

Now every member of every department can have radio communication for as little as \$49.95

Write today for further information.

- Nation's most complete line of monitor receivers.
- Crystal controlled or tunable for any VHF FM communication system.
- Mobile or stationary receivers.
- Prices to meet any budget.
- Certified for civil defense use.

MONITORADIO RADIO APPARATUS CORPORATION

55 North Jersey St., Indianapolis, Ind.

Phone: Atlantic 1624

SPLICES MAGNETIC TAPE

Neatly - Quickly - Easily

Kit includes plastic splicer which adheres to recorder or work-tape, generous supply of pre-cut tape splicing tabs, handy blade, instructions and plastic case. Only \$1.50 postpaid. If your dealer can't supply you, order from...

COUSINO, INC.

2323 Madison Ave.

Toledo 2, Ohio

TUBES

70% to 90% DISCOUNT

Government, manufacturers, jobbers, etc. surplus. Guaranteed 1 year. Free catalog on request. **CADILLAC TRADING, Dept. W, 231-07 Linden Blvd., Jamaica 11, N. Y.**

NEW LITERATURE

GENERAL RADIO BULLETINS

Bulletins on three different types of instruments are available from *General Radio Company*, 275 Massachusetts Ave., Cambridge 39, Mass. Form 873-A applies to the Type 1862-B megohmmeter which provides two test voltages—50 and 500 volts—for the measurement of high resistances. The Type 1570-A automatic line-voltage regulator, described in Form 874-A, is useful wherever it is desirable to keep the line voltage constant. In Form 875-A, Variac motor speed controls are discussed.

TRANSISTOR BIBLIOGRAPHY

Reprints of a bibliography on transistors are available gratis as long as the supply lasts from Technological Institute Library, Northwestern University, Evanston, Ill. Compiled under the direction of Alan R. Krull, Librarian, this bibliography originally appeared in the Transactions of the IRE's Professional Group on Electron Devices in August, 1954. It covers the years from 1948 through 1953, and includes some pre-1948 references which outline developments leading to the transistor.

CERAMICS BUYERS' GUIDE

Advantages of engineered ceramics over other materials and types of ceramics for specific uses are given in the new *Centralab* engineered ceramics buyers' guide. This two-color, 16-page guide is intended for use by purchasers and designers of ceramic parts; it features a tour through the *CRL* plant showing how ceramics are manufactured.

Copies of the guide (Bulletin 42-221) may be obtained from *Centralab*, 900 E. Keefe Ave., Dept. 35, Milwaukee 1, Wis.

R.F. INTERFERENCE FILTERS

Now available from *Filtron Co., Inc.*, Flushing, L. I., N. Y., is a 22-page, two-color catalog which reviews the company's standard line of Type FSR r.f. interference suppression filters for use in screen rooms, induction heating equipment, diathermy and x-ray units, or similar equipment. The FSR catalog contains cutaway illustrations, dimension drawings, graphs of attenuation characteristics and engineering data.

REGULATED POWER SUPPLIES

New Jersey Electronics Corp., 345 Carnegie Ave., Kenilworth, N. J., offers

an eight-page catalog entitled "A Sensible Approach to Regulated Power Supply Design." By standardizing the great majority of conventional power supply applications into single and multiple variations of eight basic ranges arising out of two basic circuit designs, selection of the most flexible and least expensive supply to suit a given requirement is easily made. Sixty-four variations of single and dual supplies are described.

RADIO IN MATERIALS HANDLING

"How RCA Radio Control Cuts Costs of Materials Handling" gives complete data on the ways in which two-way radio can be used to achieve substantial savings in equipment, manpower, floor space, and production time by making materials handling more efficient. Information is included on the equipment involved, how it is installed and powered, and how it is operated.

Copies of this brochure may be obtained upon request from Dept. PR 255, Building 15-1, *Radio Corporation of America*, Camden 2, N. J.

PRODELIN PRODUCTS

All products manufactured by *Prodelin, Inc.*, Kearny, N. J., are listed under one cover in this company's 1955 32-page price list. Complete descriptions suitable for ordering purposes are given

CALENDAR of Coming Events

APRIL 27-29—Seventh Region IRE Technical Conference, Hotel Westward Ho, Phoenix, Arizona.

APRIL 29-30—New England Radio-Electronics Meeting, Sheraton Plaza Hotel, Boston, Mass.

MAY 2-5—Joint URSI-IRE Spring Meeting, National Bureau of Standards, Washington, D. C.

MAY 4-6—Electronic Components Conference, U. S. Department of the Interior, Washington, D. C.

MAY 9-11—National Conference on Aeronautical Electronics, Biltmore Hotel, Dayton, Ohio.

MAY 18-20—IRE-AIEE-IAS-ISA National Telemetering Conference, Hotel Morrison, Chicago, Ill.

MAY 26-27—IRE-AIEE-RETMA-WCEMA Electronic Components Conference, Los Angeles, Calif.

Now... WITH A
SINGLE METER
TEST ALL
MOBILE
COMMUNICATIONS
EQUIPMENT



THE NEW
DUMONT
TYPE
5819-A
TEST METER

A single compact meter that permits servicing and tuning of mobile communications equipment of any make! Test connections to equipment are made through meter receptacles on all equipment so equipped. Circuits tested by turning 12-position rotary selector switch. Simple, fast, accurate! Entirely self-contained.

VERSATILE! Tests all Du Mont and competitive equipment utilizing test receptacles.

COMPACT! 9" long, 4" wide, 4" deep. Weighs less than two pounds.

PORTABLE! For field or shop use. May be used under operating conditions.

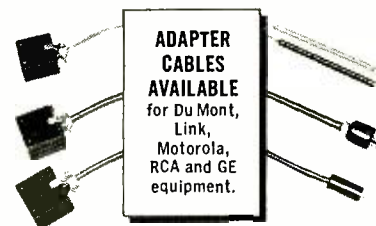

Complete Literature Upon Request

MOBILE COMMUNICATIONS DEPARTMENT R
Allen B. Du Mont Laboratories, Inc.
1500 Main Avenue, Clifton, New Jersey

Name.....

Company.....

Address.....

ennas and accessories, transmis-
line and accessories, towers and
antennas. A cross-reference index states
in what specific catalog detailed infor-
mation on a particular product can be
found.

Crystal Stability

(Continued from page 20)

of adjusting the minimum capacity re-
quired for oscillation when C_2 is at its
minimum setting.

Outputs of both crystal oscillators are
fed into two cathode followers—one for
each oscillator—which give good isolation
and offer a low impedance to the
6BE6 detector. As the detector operates
best when the amplitude of the input
signal to the control grid is larger than
that applied to the injection grid, opti-
mum input signal can be fixed at the
cathode follower inputs.

RADIO OPERATORS

Licensed operators with minimum 2 years'
marine or ground station experience.

RADIO, VHF TECHNICIANS

Minimum 5 years' experience maintaining
and installing standard commercial radio and
VHF communications equipment.

For work in Saudi Arabia.

Write giving full particulars regarding per-
sonal history and work experience. Please in-
clude telephone number.

Recruiting Supervisor, Box 4

ARABIAN AMERICAN OIL COMPANY

505 Park Avenue
NEW YORK 22, NEW YORK

Wanted — Instructors for advanced-
level Electronics, Television, and
Communications. College training pre-
ferred, but most essential qualifica-
tions are extensive experience in prac-
tical servicing with thorough theory
knowledge. Previous instruction ex-
perience in addition very desirable.
Age preferred, 35 to 50.

This is one of the Nation's oldest and
largest resident electronic schools—
an appointment to our staff would be
permanent, offering excellent oppor-
tunities.

Address complete résumé including
small photo to P. O. Box 5034, Grosse
Pointe Station, Grosse Pointe 36,
Michigan. (Our staff know of this ad-
vertisement).

MEASUREMENTS CORPORATION



Research &
Manufacturing
Engineers

Harry W. Houck John M. Van Beuren M. A. Honnell
Specialists in the Design and
Development of Electronic Test Instruments
BOONTON, N. J.

A 10-kc. resonant filter consisting of
an inductance and a capacitor is placed
in the plate circuit of the 6BE6 detec-
tor. This filter removes most of the 100-
kc. frequency, and a good 10-kc. sine
wave is obtained after the signal passes
through an additional RC filter and
amplifier.

Highly limited in a clipping stage
using a 6AU6, the 10-kc. sine wave is
formed into a square wave and used to
trigger the blocking oscillator. The
blocking oscillator is parallel-fed and a
positive pulse of $\frac{1}{2}$ μ sec. is produced.
This positive pulse is coupled to a
12AU7 clamping tube that is well biased,
and momentarily shorts the tank circuit
of the quenched oscillator.

The quenched oscillator output is then
fed into the control grid of a 6BN6
phase detector (Fig. 3B). Due to the
high limiting action of the 6BN6, all
amplitude variations are removed. Re-
ferring again to the block diagram (Fig.
1), it will be noted that a feedback loop
is created between the phase detector,
d.c. amplifier and controlled oscillator.
A small portion of the controlled oscil-
lator is compared with the quenched
oscillator; and when both oscillators are
on the same frequency, a d.c. voltage
change will occur at the plate of the
6BN6 between 0 and 90° phase differ-
ence. This voltage change controls the
d.c. amplifier which, in turn, controls a
small portion of the inductance in the
controlled oscillator plate tank circuit,
thereby completing the feedback loop
(Fig. 3B); it also serves to keep the con-
trolled oscillator in step with the
quenched oscillator. Large frequency
adjustments are made by turning the
main tuning dial.

A rather novel method is used for
resetting the controlled oscillator in the
event that control is lost in tuning from
one frequency to another. If the plate
voltage at the 6BN6 goes below normal,
a relay reacts and the variable inductance
is swept through its range and

reset as the two oscillators coincide.

Test Data

Stability measurements were made
using WWV as an absolute standard,
and a stability of .0001% was measured.
One inherent contribution to greater
stability is that the two low-frequency
oscillators are identical. If the crystals
have similar temperature characteris-
tics, any drift is in the same direction
for both, so the difference frequency re-
mains the same. Therefore, the over-all
stability is improved.

Measurements of the sideband output
showed the sidebands 10 kc. away to be
down 50 db or more from the fundamen-
tal. Additional shielding would improve
this figure.

A 10% change of the "B" supply volt-
age had no effect on the stability. When
the supply voltage was lowered more
than 10%, however, the pulse amplitude
was reduced and solid quenching was
lost.

It was found that good shielding must
be used around the two low-frequency
oscillators, and that these oscillators
should be well isolated from the other
circuitry. Particular arrangement of the
pulse-generating equipment is also re-
quired because unwanted modulation by
pulses would cause trouble. In addition,
maximum isolation of the quenched
oscillator and controlled oscillator
should be attained, as noise on the out-
put may occur due to a slight phase dif-
ference; these two oscillators must track
each other within the sweep limits of
the variable inductance.

Although the output in this particular
circuit is small, the limit of power out-
put of the controlled oscillator is re-
stricted only by the fine tuning control
element. Higher power sources of this
type are now being developed.

REFERENCE:

1. Hahn, Alvin, "Multichannel Crystal Control of V.H.F. and U.H.F. Oscillators," *Proceedings of the IRE, January, 1953.*

Fig. 3. (A) Schematic of low-frequency oscillator. (B) Schematic of phase detector.

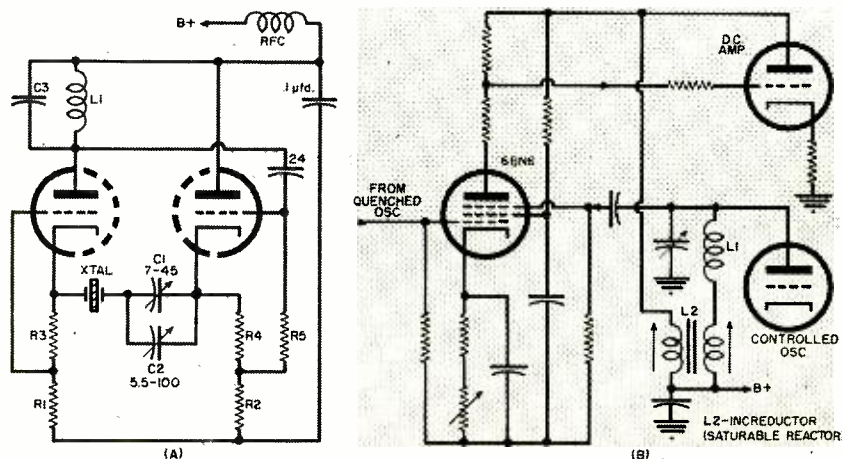

Paper Capacitors

(Continued from page 19)

effect caused by changes in standard conditions is in the external flashover voltage. For capacitors used at high altitudes, this factor must be considered, as the insulator flashover voltage may drop to values below the rated voltage of the capacitor.

Size of a.c. capacitors is determined primarily by the internal losses. Since losses increase rapidly with temperature, internal heating can become a runaway effect. The two principal losses are d.c. losses caused by leakage current and a.c. losses caused by a.c. flowing through a capacitor.

Development of new organic impregnating compounds has made it possible to extend the ambient temperature range to 125° C and above. The "Permafil" capacitors of the *General Electric Company* and the "Prokar" and "Vitamin Q" units made by the *Sprague Electric Company* are examples of high temperature paper capacitors. However, as the trend toward higher temperatures becomes more pronounced, ceramic, glass, enamel, plastic, and tantalum capacitors will be required.

Because capacitors are often subjected to wide ranges of temperature, it is important that the user be cognizant of the characteristics of the impregnants in that part of the temperature spectrum where they are used. There are many impregnants employed at the present time: mineral oil, chlorinated synthetic, castor oil, Halowax, mineral wax, polyisobutylene, polyester resins and silicone oil.

When the change in capacitance value over a wide temperature range must be small, capacitors impregnated with mineral oil or one of the new impregnants should be used. The rapid change in capacitance value of a chlorinated diphenyl unit is due to the change in dielectric constant of the impregnant. Mineral oil, silicone oil, "Vitamin Q" and "Permafil" are much more stable in this respect.

Application

The paper capacitor performs in the range between the electrolytic and mica capacitor from the viewpoint of capacitance tolerance, aging, stability with temperature and frequency, and ability to carry high currents. Generally speak-

ing, paper capacitors are satisfactory for power factor correction, low frequency filtering, blocking and bypass applications. They are reliable, and not too expensive for use in d.c. or a.c. circuits at power and radio frequencies, provided they are made carefully and used within their voltage and temperature ratings.

Proper use of capacitors in bypassing, coupling, blocking, and in timing circuits is given in WADC Technical Report 52-281. This report also contains capacitor formulas that have been found useful, and a list of recommended capacitors for a variety of common applications. For satisfactory performance in military equipment, wax-impregnated paper capacitors should be replaced with those using mineral oil, synthetic oil (polyisobutylene or silicone) or polyester resin as an impregnant.

Two properties of impregnated paper capacitors make them unsatisfactory for use in precise timing circuits—relatively low and unstable insulation resistance and high dielectric absorption. At radio frequencies, the dipolar losses in the paper may preclude the use of paper capacitors. Furthermore, because of inductance of the leads and internal connections, most paper capacitors resonate below 20 mc. However, a three-terminal "feed-thru" capacitor, such as those shown in Fig. 3, may be nonresonant up to 200 mc. or higher, depending on size.

The author acknowledges the assistance of Mr. A. A. Tiezzi, *General Electric Company*, and Mr. L. Podolsky, *Sprague Electric Company*, in reviewing this paper.

REFERENCES:

1. *Greenidge, R.M.C.*, "The Case of Reliability vs. Defective Components," *Electronic Components Symposium Proceedings*, 1953.
2. *Bennett, A. E., and Gongh, K. A.*, "Influence of Operating Conditions on the Construction of Electrical Capacitors," *Proceedings of the Institute of Electrical Engineers*, Vol. 97, Part 3, pp. 231-241, July, 1950.
3. *Brotherton, M.*, "Capacitors, Their Use in Electronic Circuits," *D. Van Nostrand Co.*, 1946.
4. *Weeks, J. R.*, "Capacitor Life Testing," *Bell Laboratories Record*, August, 1946, pp. 296 ff.
5. *Church, H. F.*, "Factors Affecting the Life of Impregnated Paper Capacitors," *Proceedings of the Institute of Electrical Engineers*, Vol. 98, Part 3, p. 52, March, 1951.
6. *Dempster, B.*, "Characteristics of Some Oil Impregnated Capacitors," *Electronics*, Vol. 21, p. 168, May, 1948.
7. *O'Bell, D. R.*, "Theory, Characteristics and Applications of Fixed Electronic Capacitors," *WADC Technical Report No. 52-281*, December, 1952.

Extra Rugged—Light Weight
HIGH ARTICULATION
E-V
Mobile-Mikes



CARBON AND DYNAMIC TYPES

E-V Mobile-Mikes are designed for the ultimate in speech transmission! You get high intelligibility, high output, more usable power level, less listener fatigue and other E-V features. *Proved in toughest service.* Used in public safety, aircraft, railroad and government communications. High impact phenolic case. Permanent finish. Weighs as little as 7 oz. Model 210 Carbon lists at \$28.50. Model 600-D Dynamic lists at \$38.50.

EXACT REPLACEMENT

Carbon Mobile-Mikes also available for exact replacement in current Motorola, RCA, G.E. and similar equipment. You get full advantage of E-V design and performance features.



NOISE-CANCELLING DIFFERENTIAL*



Close-talking, carbon type. Assures clear speech transmission under high ambient noise in any weather or climate. Blast-proof, waterproof, shock-resistant. Model 205 lists at \$38.50. Model 602 Differential Dynamic at \$49.50 list. (*Patent No. 2,350,010)

Send for Bulletin!

Electro-Voice

BUCHANAN, MICHIGAN
Export: 13 E. 40th St., N.Y. 16, U.S.A., Cables: Arlab

AUTHORIZED DISTRIBUTORS EVERYWHERE

INDEX OF ADVERTISERS

NAME	PAGE	NAME	PAGE
Arabian American Oil Company.....	30	Hickok Electrical Instrument Co., The...	27
Bendix Aviation Corp.....	25	Industrial Transformer Corporation.....	26
Bruno-New York Industries Corporation...	23	Measurements Corporation.....	30
Cadillac Trading.....	28	Monitoradio Radio Apparatus Corp.....	28
Chicago Standard Transformer Corp.....	4	Precision Paper Tube Co.....	21
Cousino, Inc.....	28	Pye Limited.....	3
Du Mont Laboratories, Inc., Allen B....	29	Radio Corporation of America.....	6
Electro-Voice.....	31	Radio Engineering Products.....	25
Freed Transformer Co., Inc.....	Fourth Cover	United Transformer Co.....	Second Cover

FREED MINIATURE PULSE TRANSFORMERS

USED IN UNIQUE BLOCKING OSCILLATOR CIRCUIT CAN PASS UP TO 200,000 PULSES PER SECOND.

Freed Miniature Pulse Transformers are being used in a novel blocking oscillator circuit which produces sharp pulses at repetition rates up to 200,000 pulses per second. With the circuit constants shown, an output pulse of two microseconds duration, 65 volts amplitude can be obtained with a p.r.f. of 20,000. The rise time obtained with the FREED MPT-8 is less than 0.05 microsecond. This fast repetition rate circuit can be triggered with either a sine or a square wave, and requires a driving voltage of anywhere from one to fifty volts. The bias voltages need not be obtained from a low impedance supply. If a negative pulse output is required, the FREED MPT-7 transformer provides a tertiary winding for this purpose.

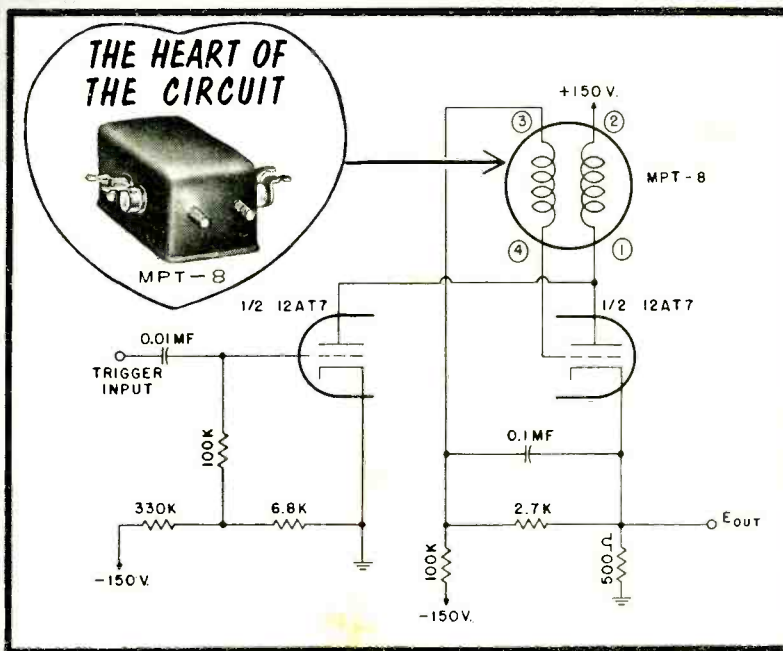

HERMETICALLY SEALED PULSE TRANSFORMERS for use in blocking oscillators, low level interstage coupling, and modulator outputs. Made in accordance with MIL-T-27 specifications. These pulse transformers are designed for maximum power, efficiency and optimum pulse performance. Balanced coil structures permit series or parallel connection of windings for turn ratios other than unity. Pulse characteristics, voltages and impedance levels will depend upon interconnections made.

Catalog Number	Application	Pulse Voltage Kilovolts	Pulse Duration Microseconds	Duty Ratio	Test Voltage KV., RMS	Characteristic Impedance Ohms	Case Size
MPT-1	Blocking oscillator or interstage coupling.	0.25/0.25/0.25	0.2-1.0	.004	0.7	250	DM-12
MPT-2	Blocking oscillator or interstage coupling.	.025/0.25	0.2-1.0	.004	0.7	250	DM-12
MPT-3	Blocking oscillator or interstage coupling.	0.5/0.5/0.5	0.2-1.5	.002	1.0	250	DM-18
MPT-4	Blocking oscillator or interstage coupling.	0.5/0.5	0.2-1.5	.002	1.0	250	DM-18
MPT-5	Blocking oscillator or interstage coupling.	0.5/0.5/0.5	0.5-2.0	.002	1.0	500	DM-12
MPT-6	Blocking oscillator or interstage coupling.	0.5/0.5	0.5-2.0	.002	1.0	500	DM-12
MPT-7	Blocking oscillator, interstage coupling or low power output.	0.7/0.7/0.7	0.5-1.5	.002	1.5	200	DM-18
MPT-8	Blocking oscillator, interstage coupling or low power output.	0.7/0.7	0.5-1.5	.002	1.5	200	DM-18
MPT-9	Blocking oscillator, interstage coupling or low power output.	1.0/1.0/1.0	0.7-3.5	.002	2.0	200	DM-18
MPT-10	Blocking oscillator, interstage coupling or low power output.	1.0/1.0	0.7-3.5	.002	2.0	200	DM-18
MPT-11	Blocking oscillator, interstage coupling or low power output.	1.0/1.0/1.0	1.0-5.0	.002	2.0	500	DM-01
MPT-12	Blocking oscillator, interstage coupling or low power output.	0.15/0.15/0.5/0.5	0.2-1.0	.004	0.7	700	DM-8

Send for further information and catalog

FREED TRANSFORMER CO., INC.

1719 Weirfield St., Brooklyn (Ridgewood) 27, N. Y.

OTHER FREED PRODUCTS TRANSFORMERS

- High Fidelity
- High Level Pulse
- High Q Toroids
- Power
- Slug-Tuned
- Hermetically Sealed
- Step-down
- Magnetic Amplifiers
- Miniature Transistor
- High Q Reactors
- High Temperature
- Miniature Audio
- Charging Reactors
- Sub-Miniature
- Precision Reactors
- Precision Filters

INSTRUMENTS

- Comparison and Limit Bridges
- Low Frequency "Q" Indicators
- Incremental Inductance Bridges
- Universal Bridges
- Null Detectors and V.T. Voltmeters
- Power Supplies
- A.C. Bridges and Accessories
- Differential Voltmeters
- Harmonic Distortion Meters
- Wide Band Amplifiers
- Decade Amplifiers
- Decade Inductors
- Decade Capacitors
- Megohmmeters
- Filters
- Magnetic Voltage Regulators